

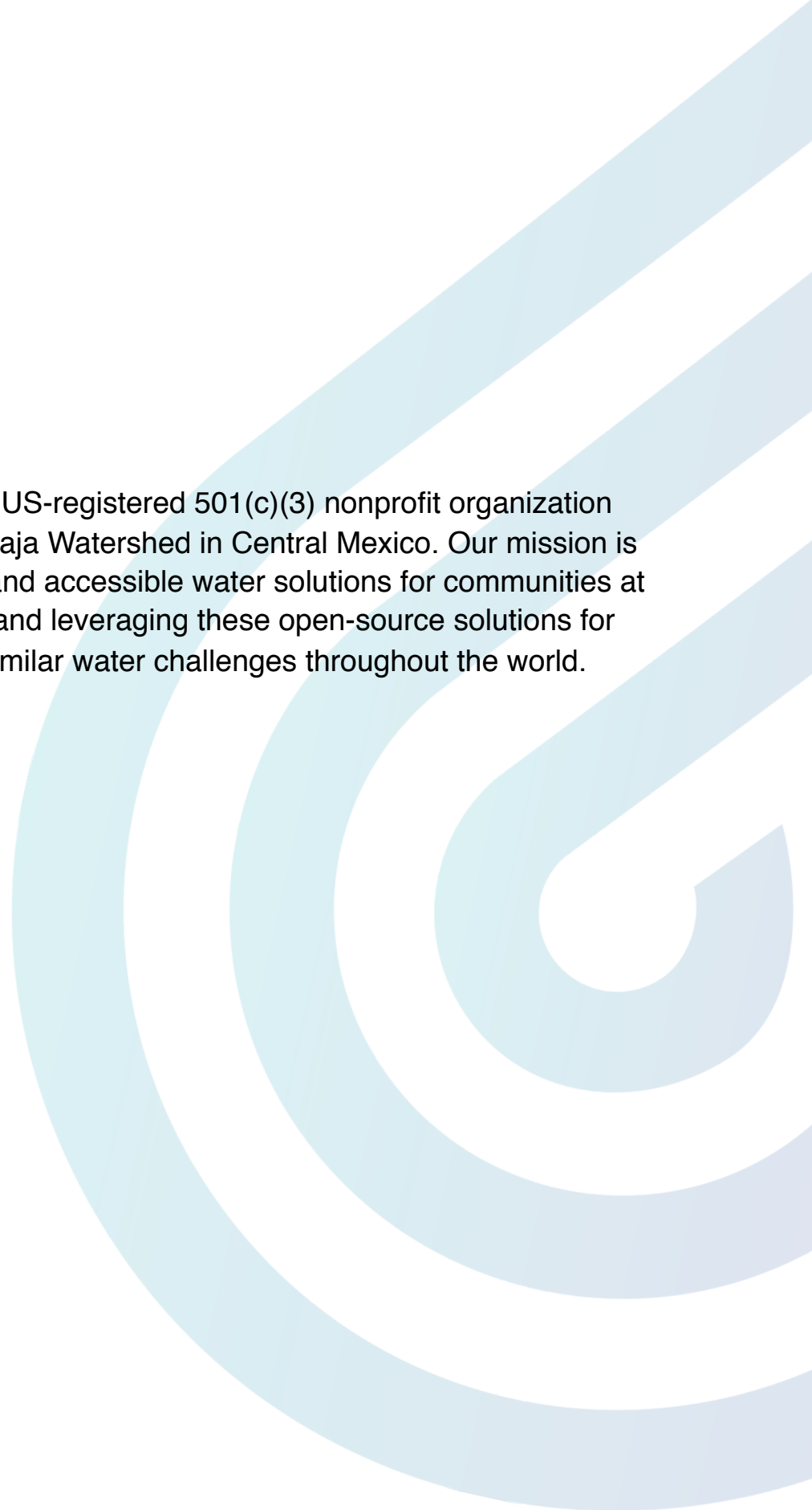
A large white cylindrical rainwater storage tank is the central focus. A man in a blue and green striped shirt and a baseball cap is sitting on the ground next to the tank, filling a container from a tap. The background shows a brick roof and a cloudy sky.

HARVESTING A HEALTHY FUTURE

2nd Edition, 2018

Caminos de Agua

Manual for the capture, storage, and treatment of rainwater – using low-cost systems – to provide a source of safe, healthy, and accessible drinking water.



Caminos de Agua is a US-registered 501(c)(3) nonprofit organization working in the Alto Rio Laja Watershed in Central Mexico. Our mission is providing safe, healthy, and accessible water solutions for communities at risk in our watershed, and leveraging these open-source solutions for others confronting similar water challenges throughout the world.

HARVESTING A HEALTHY FUTURE

2nd Edition, 2018

Caminos de Agua

Manual for the capture, storage, and treatment of rainwater — using low-cost systems — to provide a source of safe, healthy, and sustainable drinking water.

Acknowledgments

Caminos de Agua is grateful for the support of Lucha Villafuerte and United Communities for Life and Water, Father Juan Carlos Zesati and the San Cayetano Community Center, Carmen Castro and Pozo Ademado Community Services, and Henry Miller and El Maíz Más Pequeño. We extend our deepest gratitude to the people of the communities of the Alta del Rio Laja and Laguna Seca sub-basins, who have invited us into their homes and at their tables, and who continue to struggle for access to safe, healthy, and sustainable drinking water every day.

Harvesting a Healthy Future

Manual for the capture, storage, and treatment of rainwater — using low-cost systems — to provide a source of safe, healthy, and sustainable drinking water.

Written, Organized, Translated, and Edited by Caminos de Agua

Casilda Barajas Rocha
Elena Diek
Chantal Kronenburg
Aaron Krupp
Sarah Mitchell
Pilar Quintanilla Martinez
Dylan Terrell
Daniela del Villar

Diagrams, Drawings, and Graphic Design

Elena Diek
Aaron Krupp

Photography

Janet Jarman
Cameron Plese (coverfoto)
William Thurston
Selene Trapp

For more information regarding this manual:

Caminos de Agua
Allende #5, Colonia Insurgentes, San Miguel de Allende, Gto, México 37712
Tel: 415-154-8091 / Email: info@caminosdeagua.org
www.caminosdeagua.org



Harvesting a Healthy Future, Caminos de Agua
2017

© 2017 by Caminos de Agua. This work is licensed under the Creative Commons Attribution 4.0 International License. To view a copy of this license, visit: <http://creativecommons.org/licenses/by/4.0/>.





“When the well runs dry, we know the worth of water.”

- Benjamin Franklin

Contents

Chapter 1. Introduction	10
1.1 About this manual	10
1.2 Rainwater harvesting background	11
1.2.1 Why harvest rainwater?	11
1.2.2 Is rainwater harvesting right for you?	11
1.2.3 How do you harvest rainwater?	12
1.2.4 How can you use this manual to build a rainwater harvesting system?	12
Chapter 2. Before building	14
2.1 Components of a rainwater harvesting system	14
2.2 Calculating your capacity	15
2.2.1 Average monthly rainfall	16
2.2.2 Roof surface area	16
2.2.3 Calculating your cistern size	17
2.3 Preparation of a rainwater harvesting system	18
2.3.1 Location of the cistern	18
2.3.2 Preparing the location	19
2.3.3 Timing the construction process	19
Chapter 3. Cisterns	20
3.1 General cistern considerations	20
3.1.1 Filling the cistern	21
3.1.2 Getting water out for regular use	22
3.1.3 Overflow	24
3.1.4 Flushing	25
3.1.5 Connecting multiple cisterns	25
3.1.6 Air	27
3.1.7 Mesh screens	27
3.2 Building a 12,000 liter ferrocement cistern	28

3.2.1	Welding preparation	28
3.2.1.1	Drinking water tap nipple	29
3.2.1.2	Cistern roof door	30
3.2.2	Tools & materials	38
3.2.2.1	Tools	38
3.2.2.2	Materials	39
3.2.3	Reinforcement	41
3.2.3.1	Weaving the mesh	41
3.2.3.2	Cutting the mesh	48
3.2.3.3	Assembling the cylinder	48
3.2.3.4	Assembling the roof reinforcement	51
3.2.4	Cistern base	53
3.2.5	Cistern wall	58
3.2.5.1	Attaching the formwork	58
3.2.5.2	Applying concrete layers	61
3.2.6	Cistern roof	70
Chapter 4. Roofs and gutters		76
4.1	Concrete gable roof	77
4.1.1	Materials	78
4.1.2	Tools	78
4.1.3	How to build the brick wall for a concrete gable roof	79
4.2	Concrete flat roof	82
4.1.1	Materials	82
4.3.2	Tools	83
4.3.3	How to build the brick wall for a concrete flat roof	83
4.4	Corrugated sheet, tile, and shingled roofs	87
4.4.1	Tube harvester materials	87
4.4.2	Tube harvester tools	88
4.4.3	How to build and install a tube harvester	88
Chapter 5. First flush systems		92
5.1	First flush practical considerations	92

5.1.1	Sizing your first flush	93
5.1.2	Different types of first flushes	94
5.2	Building a barrel first flush system	96
5.2.1	Tools	96
5.2.2	Materials	96
5.2.3	Steps to build a barrel first flush system	97
5.3	Building a PVC first flush system	101
5.3.1	Tools	101
5.3.2	Materials	102
5.3.3	Steps to build a PVC first flush system	103
Chapter 6. Connecting it all: Gutter and pipes		108
6.1	Design considerations	108
6.1.1	Choosing a type of pipe	108
6.1.2	Choosing a pipe diameter	108
6.1.3	Sun damage on plastic	109
6.1.4	Structural integrity	109
6.1.5	Leaf filters	109
6.1.6	Heights, gravity, and paths	110
6.2	Specific assembly guidelines	110
6.2.1	Drilling holes for fittings	111
6.2.2	Bulkhead fittings vs. internally/externally threaded PVC couples	112
6.2.3	Gaskets, o-rings, & silicone	113
6.2.4	Strong PVC connections	114
6.3	System photos	115
Chapter 8. Maintenance		118
8.1	The roof	118
8.2	Leaf filters	118
8.3	Gutters & piping	118
8.4	First flush system	119

8.5	Cistern	119
8.6	Caminos de Agua ceramic candle filter	119
Chapter 7. Biological treatment		121
7.1	Practical low-cost treatment methods	122
7.1.1	Boiling	123
7.1.2	Solar disinfection (SODIS)	124
7.1.3	Biologically active slow-sand filtration	125
7.1.4	Ceramic pot filtration	126
7.1.5	Chlorine	127
7.1.6	Distillation	128
7.1.7	Ceramic candle filtration*	129
7.1.8	Caminos de Agua's ceramic candle filter	130
7.2	Safe water storage	133
7.3	Higher-cost and proprietary treatment methods	135
7.4	Connecting your rainwater system to treatment & storage	136
Appendix A: Design worksheets		139

Chapter 1. Introduction

1.1 About this manual

We all need water. Water should be a basic human right, but not all of us have access to safe and healthy drinking water. Daily, a single person needs at least five liters of healthy and safe water for drinking and cooking. Rainwater harvesting can be an effective way to meet this essential water need when a community has limited water access and/or has to deal with contamination issues. This manual provides a rigorous introduction to rainwater harvesting, contains tools on system sizing and location assessment, and includes a step-by-step guide on constructing, installing, and maintaining a rainwater harvesting system.

This manual was created by Caminos de Agua, a 501(c)(3) nonprofit organization that creates low-cost, high impact solutions to challenges in safe, healthy, and sustainable water for people. We believe that all people should live in an ecologically healthy environment with access to safe and healthy drinking water. We primarily work in seven municipalities, connected by water, in northern Guanajuato state, Mexico. We focus on creating solutions for this small, water-scarce region, but our open-source technology often has global applicability. We hope that our research and technologies — available for free globally with a Creative Commons license — will be useful to people, communities, organizations, and governments, striving for a sustainable future.

Although the technologies described in this manual were developed in and for central Mexico, they are all useful worldwide with a bit of adjustment. For example, we provide tools in chapter 2 for sizing your system depending on your monthly rainfall, regardless of where in the world you live. Additionally, almost all of the materials used in this manual including PVC, cement, basic manual tools, and chickenwire are available globally. And while this manual focuses on building a free-standing ferrocement cistern, many of the principles apply to other building methods like masonry or bamboo-reinforced concrete. If you choose to install a plastic tank, underground cistern, or geomembrane, chapters 4-8 — which describe the rest of a rainwater harvesting system — remain relevant. We hope that this manual helps you build safe, healthy, and sustainable water access for your community.

1.2 Rainwater harvesting background

1.2.1 Why harvest rainwater?

Rainwater harvesting is a simple, inexpensive, and sustainable way to secure water for rural and urban communities. Rainwater harvesting eases stress on underground aquifers, which are often overexploited and being quickly depleted throughout Mexico and around the globe. As more communities begin to use rainwater for their daily consumption, our aquifers will begin to recharge — a process that will, in some parts of the world, take thousands of years. Since we can continue to use rainwater harvesting systems for the indefinite future without compromising our or the planet's health, rainwater is considered a *sustainable* water source.

Rainwater is also considered a *healthy* water source because it is free of contaminants that lead to long-term health problems. Groundwater can contain heavy metals and minerals, some of which cause developmental disorders, cancers, and acute poisoning. Due to industrial dumping and inadequate corporate regulation, surface and shallow well waters including rivers, canals, lakes, and reservoirs are often contaminated with agrochemicals and other toxins known to cause organ failure, neural degradation, and reproductive disorders. Harvesting and consuming rainwater supports ecologically sustainable and healthy lives across generations.

1.2.2 Is rainwater harvesting right for you?

Building a rainwater harvesting system is easy and relatively low-cost. Rainwater harvesting systems, if built well, can provide some of the safest and healthiest water found on Earth. However, if poorly constructed or designed, can be a source of contamination and disease. If you decide to build a rainwater harvesting system, make sure that you are making your best effort to eliminate contamination risk at every step.

Rainwater is both safe — free from biological pathogens — and healthy — free from mineral or chemical contaminants — almost everywhere in the world. However, if you live in a place with severe air pollution, rain can pick up toxic chemicals as it falls. If this is the case, *rainwater harvesting is probably not right for you*. Additionally, once the rain hits your roof, it will pick up some chemical contaminants from your roof and some biological contaminants. The biological contaminants are easy to safely remove with a few basic precautions (see chapter 7). Toxic chemical from your roof like asbestos and lead, for example, can be dangerous. If you are considering harvesting rainwater, make sure your roof is not leaching harmful chemicals. Concrete, most plastics, and most ceramics tend to be safe, but it is still worth checking with your local supplier or builder.

1.2.3 How do you harvest rainwater?

Great question. You've come to the right place. Rainwater harvesting is easy to apply on a household level since you can use any roof to catch rainwater. Water flows naturally, with help from gravity, off the roof and into a gutter or piping system. The pipes separate the first liters of water — which carry all the dirt, dust, leaves, and bird feces that have accumulated since the last rainfall — into a first flush system, cleaning the roof. The rest of the water flows into the cistern, a large tank for long-term water storage. Although the first flush system diverts most of the dangerous contaminants, the water in the cistern will still have some biological activity. Therefore, before consuming the water, it should always be treated for biological contaminants with a filter, chlorine, iodine, UV disinfection, colloidal silver, or a number of other treatment methods (see chapter 7).

Before building a system, however, it is important to determine how much water you can capture in your region — with your available roof area — and how large your cistern should be. In our region in northern Guanajuato, Mexico, it takes four to six square meters of roof and about 800 liters of storage capacity to support one person's essential consumption for a year. In each part of the world, these numbers will vary drastically, depending on local rainfall. If you live in a place with a long dry season, your rainwater system needs to store enough water to support your community through that time. Make sure to consult chapter 2 to determine how to best design a system for your region.

1.2.4 How can you use this manual to build a rainwater harvesting system?

The rest of this manual contains details, descriptions, photos, schematics, and step-by-step instructions on how to build your own system to harvest rainwater easily and sustainably:

Chapter 2 provides information to consider before building a system. It describes a complete system in greater detail, provides background calculations necessary to size your system, and describes preliminary requirements for the system's location.

Chapter 3 contains general cistern considerations followed by step-by-step instructions for building a 12,000-liter ferrocement (iron-reinforced concrete) cistern. We have chosen a 12,000-liter ferrocement cistern because most of the communities where we work suffer from severe water scarcity — receiving water only several times a week or month in many cases — as well as groundwater contamination (arsenic and fluoride). A 12,000-liter cistern can often serve several families' drinking and cooking needs for a year or subsidize one family's other water needs. Additionally, our region has plentiful labor but not much extra money; ferrocement is labor-intensive but low-cost.

Building the cisterns has also been a valuable exercise in teamwork, collaboration, mutual respect, and organizing. If you choose to use another type of cistern — plastic, underground, masonry, bamboo-reinforced concrete, geomembrane, etc. — you can mostly skip chapter 3, however it may be worth a skim to understand the valves and connection points.

Chapters 4, 5, and 6 focus on installing your system: roof connections and gutters, leaf filters, the first flush system, and plumbing and piping. These instructions apply regardless of what type of cistern you build.

Chapter 7 explains how to integrate biological treatment to your system so that your water is not only healthy and sustainable, but also *safe* to drink everyday.

Chapter 8 describes how to maintain your complete rainwater harvesting system. When properly cared for, a rainwater system can provide safe, healthy, and sustainable water for decades while demonstrating that humans can maintain a sustainable and regenerative relationship with Earth's water supply.

Chapter 2. Before building

Before building a rainwater harvesting system, read through this chapter to understand the system, determine the size required to meet your needs, and prepare the location for harvesting rainwater.

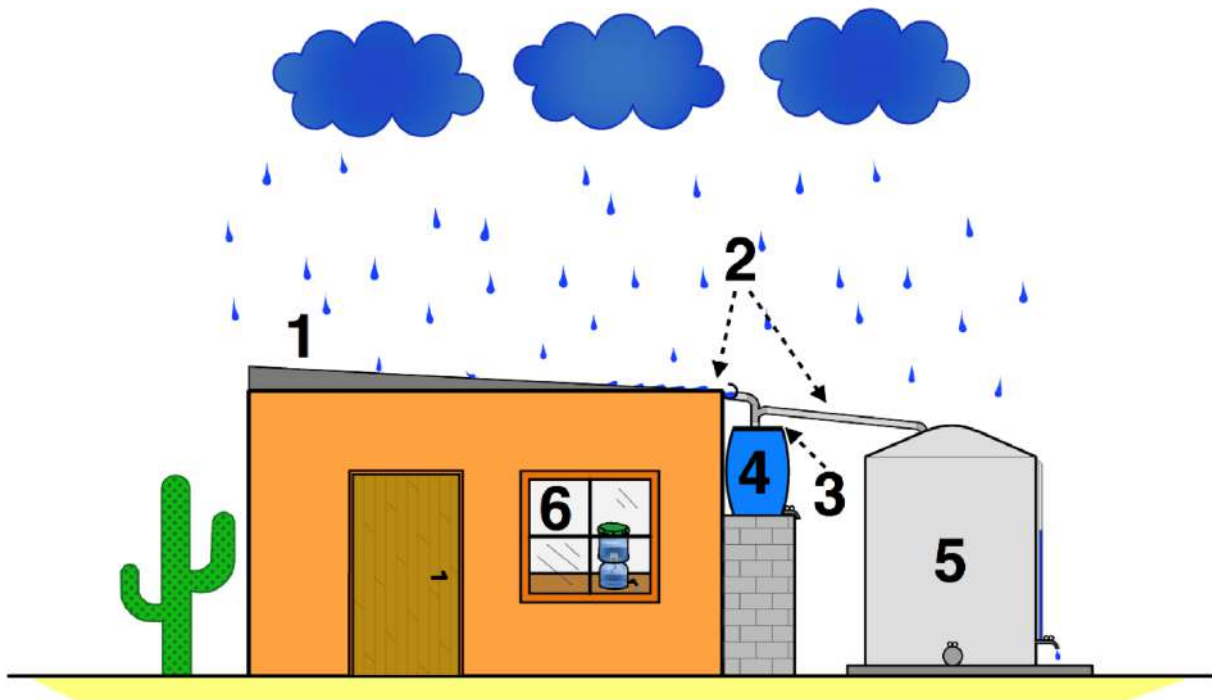


Figure 2.1 — The six components of a rainwater harvesting system (1) roof, (2) gutters and pipes, (3) leaf filters, (4) first flush, (5) cistern, and (6) biological treatment.

2.1 Components of a rainwater harvesting system

All rainwater harvesting systems have six central components as shown in *figure 2.1*.

1. **Roof:** The roof surface captures rain.
2. **Gutters and Pipes:** Gutters are the horizontal pipes or ducts that direct captured rainwater from the roof. Pipes transport harvested water throughout the system.
3. **Leaf filters:** All entrances and exits must be covered with a leaf filter that prevents leaves, trash, and even small animals and insects from getting into the system.

4. **First flush:** A first flush system separates the first harvested rain from each rainfall to ensure that the rainwater that enters your main water storage is as clean as possible. It will keep dust, leaves, mud, debris, animal droppings, and potential biological organisms from entering the cistern. Water collected in a first flush system is not meant for drinking and cooking but is great for watering your garden, for instance. There are different types of first flush systems which can be constructed with barrels, PVC piping, or other containers.
5. **Cistern:** the cistern is the main storage for your harvested rainwater and can be free-standing, as pictured, or underground.
6. **Biological Treatment:** Rainwater is free of chemicals, heavy metals, and minerals but it is still at risk for pathogens, bacteria and other biological contaminants. ALWAYS treat your harvested rainwater for these biological contaminants before consuming.

Rainwater harvesting in combination with biological treatment is a safe, healthy, and sustainable water solution.

2.2 Calculating your capacity

One person needs five liters of water for drinking and cooking, called their “essential need”, every day. If your roof is large enough to capture extra water, you can use it for other activities like showering, watering a garden, feeding livestock, or hand washing.



There are three crucial variables that determine the amount of rainwater you can harvest:

1. Rainfall
2. Roof surface area
3. Size of space for water storage

First, the average rainfall of your location determines how much water is available to harvest. Average monthly rainfall is necessary to calculate the exact amount of rainwater you can collect *on the average year*. Since half of the years, on average, yield less rain than average, make sure to add 25% to your calculation. The calculation is also possible with yearly rainfall data, but monthly data provides a more accurate picture of your region’s water scarcity. For example, a region that gets 30 centimeters of rain every month gets the same annual rainfall as an area that gets 360 centimeters over the summer monsoon, and is completely dry for the remaining nine months. The

person in the monsoon region needs a much larger cistern because they need to subsist off of stored water for a nine month dry-spell every year.

Second, the size of your roof determines the maximum amount of water you can catch.

Finally, you need to know if you have enough space to store the amount of rainwater you plan to harvest. Knowing these three variables will tell you if rainwater harvesting is an appropriate solution for your household.

2.2.1 Average monthly rainfall

To find your region's average monthly rainfall, we recommend looking up a nearby rain-station online. You can look up the website of a local university or government agency that monitors the weather, or you can try one of these general sites:

- World Weather & Climate Information: <https://weather-and-climate.com>
- World Weather Online: <https://www.worldweatheronline.com>
- Climate-Data.org: <https://en.climate-data.org>
- Weatherbase: <http://http://www.weatherbase.com>

If none of those work, just try Googling for your city, town, or community with “average monthly rainfall.” If you do not have access to the internet, reach out to a local university, government agency, or non-governmental organization that monitors climate and weather. Many of them will give you average monthly rainfall data for free. Try to make sure that the data you are using goes back at least twenty years to get a more reliable answer.

Note: as the climate changes and the Earth warms, weather patterns will change unpredictably. Some places will get more rain, others less. When you are collecting your region's average monthly rainfall, it is safer to assume that your average monthly rainfall will decrease over the next few decades. Size your cistern appropriately.

2.2.2 Roof surface area

To determine how much water you can collect, calculate the total area of you collection surface(s). These could include the roofs of a house, garage, shade structure, green house, parking lot, and more. You can connect as many roofs as you would like to the same cistern as long as the first flush system is sized appropriately (see *chapter 4*).

To calculate the area of a roof, simply multiply the length by the width, as shown in equation 1:

$$A_{roof} = L \times W \quad (1)$$

To measure the length and width of your roof, measure the dimensions shown in figure 2.2. You can often do so without even using a ladder. Notice, however, that figure 2.2 shows the width of both the left and right sides of the roof. If you only intend to collect rain from one side, you would use half of the width shown.

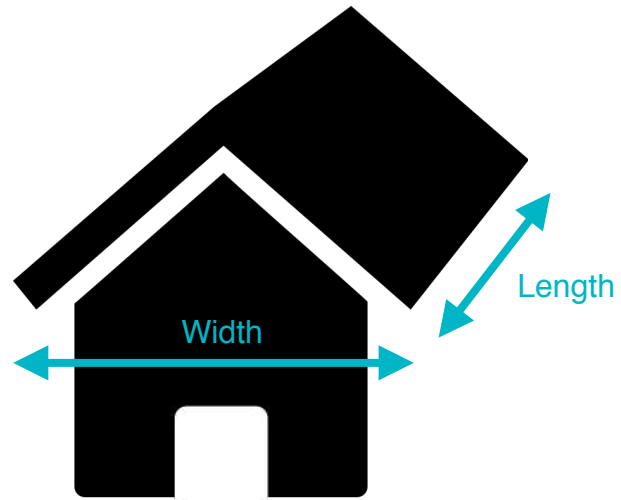


Figure 2.2 – Width and length of a roof

Additionally, notice how you are not actually calculating the surface area of your roof, rather the projection of the area onto the top of the house. This is because we assume that rain is falling down, not sideways, therefore a normal-sized house with a tall roof would fare no better than its flat-roofed neighbor. In reality, of course, this assumption is not true. Rain hits a roof at an angle, which depends on the speed of the wind. Since that is excessive information for our purposes, we will assume that the rain falls vertically from the sky and the length and width, as shown in figure 2.2, will suffice.

2.2.3 Calculating your cistern size

Now that you know your average monthly rainfall data and your roof area, let's figure out how large your cistern needs to be for your household or community. There are a number of ways to do this calculation. The easiest (and the one we most highly recommend) is online, using our free rainwater harvesting system calculator at:

<https://caminosdeagua.github.io/calculadora-captacion-lluvia>

Since all of these calculations are done using average data, make sure to add 25% to the result to account for less-than-average rainfall years.

If you do not have access to the internet, and you live in San Miguel de Allende municipality, Guanajuato, México, see appendix A where you can do the calculation manually.

If you do not have access to the internet and do not live in San Miguel de Allende, you can do a very basic calculation to figure out how much water you can harvest in a year:

$$V_{max} = R_{annual} \times A_{roof} \times \epsilon \quad (2)$$

where V_{max} is the volume of rain you can harvest over an entire year, R_{annual} is the annual rainfall (which you can calculate by adding up all your monthly rainfalls from section 2.2.1), A_{roof} is the area of your roof from section 2.2.2, and ϵ is the efficiency factor of your roof (see figure 2.3). This calculation for V_{max} tells us how much water you can capture in a year. This is not very useful, because you will probably not just let your cistern fill up for a year without drinking anything. However, it does give us an upper limit for how much water you can collect off of your roof. If you can afford a cistern that large, go ahead and build it. Otherwise, a cistern half as large or smaller should suffice to capture all the water off your roof as you simultaneously use it.

Roof	Efficiency factor (ϵ)
Concrete	0.85
Corrugated sheet	0.8
Spanish tile	0.8
Other	0.75

Figure 2.3 – Efficiency factors for various roof types

The final step is choosing a location for your cistern. Of course, the space must be large enough and able to support the weight of water, but there are many other important considerations when considering a cistern location - covered in the next section.

2.3 Preparation of a rainwater harvesting system

Before beginning construction on your rainwater harvesting system, there are a few important preparations to undertake. This chapter guides you through picking a location, preparing the location, and planning your construction process.

2.3.1 Location of the cistern

The first step in building a rainwater harvesting system is choosing an appropriate place for the cistern. Make sure to consider the following points when assessing a location:

- A cistern uphill from the point of use allows you to take advantage of gravity for water transport.
- The cistern should be accessible for easy construction and maintenance.
- The closer the cistern is to the roof, the shorter the piping systems can be.
- It can be useful to have the cistern close to the kitchen or wherever you use the most water.
- The cistern needs to sit on flat ground.
- Trees close to the cistern are useful: they provide shade and slow the growth of algae; however, trees overhanging the collection surface will dirty the roof with leaves, bark, and bird droppings and contaminate the water.

2.3.2 Preparing the location

Once the cistern's location is determined, it needs some preparation. Make sure to:

- Prune all trees that overhang the roof. Keep them pruned while your system is in use; leaves, bark, and feces can endanger your water supply and health.
- Flatten the land in a 3x3 meter square where you will build the cistern. This can be done with shovels, trowels, and/or a compacting tamper tool or machine.
- Ensure the the ground is free of any large debris.
- If it could rain or if the construction site is in the direct sun, put up a structure (a tarp tied between trees will do) to provide shade for workers and the cement or to keep the rain off the construction.

2.3.3 Timing the construction process

When planning your cistern, consider the weather. It probably does not make sense to work during a monsoon, for example, since heavy rains can destroy wet cement and make working outdoors unpleasant. Be prepared for working outside all day, for many days in a row! If necessary, prepare a shade or water-proof structure to protect your worksite. Additionally, if you want your cistern to fill quickly, it should be ready by the beginning of the rainy season. Therefore, we recommend beginning the construction process a few months before the rainy season, giving your cistern ample time to cure before being filled with safe, healthy, and sustainable water.

Chapter 3. Cisterns

Now that you have chosen and prepared your site, it is time to plan and build your cistern. This chapter is divided into two sections: general planning considerations (3.1) and step-by-step instructions for constructing a 12,000 liter ferrocement cistern (3.2).

Section 3.1 covers how to get water into and out of the cistern, overflow, flushing, connecting multiple cisterns in series and parallel, and how to manage cistern pressure. This section applies to any free-standing cistern including systems made from masonry, fiberglass, plastic, geomembranes, bamboo-reinforced cement, and ferrocement, among others. Underground cisterns function a bit differently, but many of the same principles apply.

Section 3.2 details the specific steps of building a 12,000 liter ferrocement cistern. This is the cistern the we primarily build in rural central Mexico. Many of the techniques apply to other cement-based designs like masonry or bamboo-reinforced concrete.

Good luck building your cistern!

3.1 General cistern considerations

Read this section *before* constructing or installing your cistern. While chapter 2 discussed the site, this chapter focuses on design considerations related to the cistern itself. These include:

- 3.1.1 Filling the cistern
- 3.1.2 Getting water out for regular use
- 3.1.3 Overflow
- 3.1.4 Flushing
- 3.1.5 Connecting multiple cisterns
- 3.1.6 Air
- 3.1.7 Mesh screens

While there are limitless ways to address these design considerations, some methods may serve your purposes better than others. Make sure to carefully consider the following sections when planning your cistern.

3.1.1 Filling the cistern

To fill your cistern, you need to consider the following components: 1) collection surface, 2) gutters, 3) the first flush system, and 4) cistern entry (see section 2.1 for details). For this manual, we will assume you are collecting water off of a roof, allowing you to take advantage of gravity to fill the cistern. If you are collecting off of a lower surface, like a road or parking lot, there are different considerations that fall outside the scope of this manual.

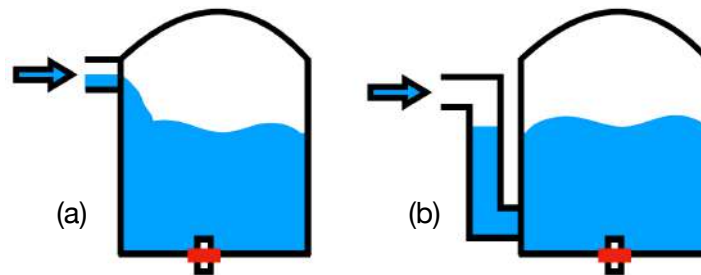


Figure 3.1 — How rain can enter the cistern.

The arrows indicate the direction of water flow. Design (a) puts new water at the top, prevents buildup in the pipes, and ensures that the water that you are drinking is the oldest in the cistern while promoting mixing. Design (b) allows water to stagnate in the pipes, for old water to build up in the cistern, and disturbs settled sediment.

As the water flows off of the roof (see chapter 4), capture it in a gutter system. Make sure that all of your piping flows downhill, otherwise the water will build up.

A first flush system is crucial to making sure the water that enters your storage system is of high physical quality. Sizing and building an appropriate first flush system are covered in greater detail in chapter 5.

Although you could successfully have the water enter from the bottom or top of the cistern, as shown in *figure 3.1*, in almost every case it is better to add water from the top. If the water enters through the bottom, it will build up in the pipes and stagnate. Additionally, if any sediment makes it way into the cistern, it will settle to the bottom. If the rain enters through the bottom, it will stir up the sediment and your water will come out dirtier. Finally, a bottom-entry leads to more plumbing connections the experience high pressure and create more potential points of failure.

3.1.2 Getting water out for regular use

Without being able to use the water, what's the point of having a cistern? This section describes important design factors to consider when designing your cistern's tap or daily-use outlet.

As shown by the red dimension in *figure 3.2*, the tap is not at the bottom of the cistern (also see *figure 3.4*). Instead, it is elevated from a few centimeters to half a meter. The height of your tap will depend on the type of cistern, ambient weather conditions, and how you intend to use the cistern.

A few practical considerations:

Sediment — There will be at least some sediment in your cistern. The cistern acts as a settling tank, letting the sediment fall to the bottom. Make sure the valve is raised at least 5 centimeters to not disturb this layer of old water and accumulated sediment.

Practical use — You need to be able to remove water from your cistern. If you plan to walk to the cistern with a bucket or container to fill with water, obvious as it may seem, that container must fit between the tap and the ground. On the other hand, if you are going to connect a hose to the cistern, you need much less clearance. If you are going to pipe the water into a building, you don't need any clearance, except the clearance defined above to trap sediment.

Besides the height of the tap, you also need to consider the type of tap. Typically this depends on how much control you would like over the flow. If you just want an on/off switch, using a standard ball valve (*figure 3.3a*) is sufficient. But if you want more fine control, a globe valve (*figure 3.3b*) is often more appropriate.



Figure 3.2 — Height of tap from ground

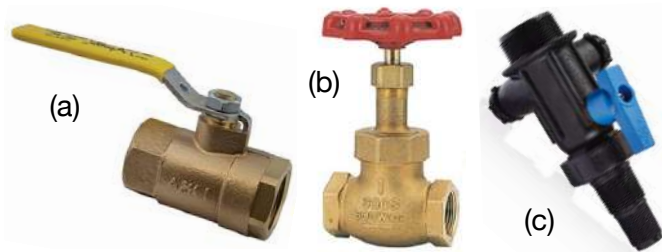


Figure 3.3 — Taps for a standard cistern outlet
(a) a ball valve allows you to turn the cistern on and off, (b) a globe valve gives you more precise control, (c) many commercial plastic cisterns come with a valve like this one.

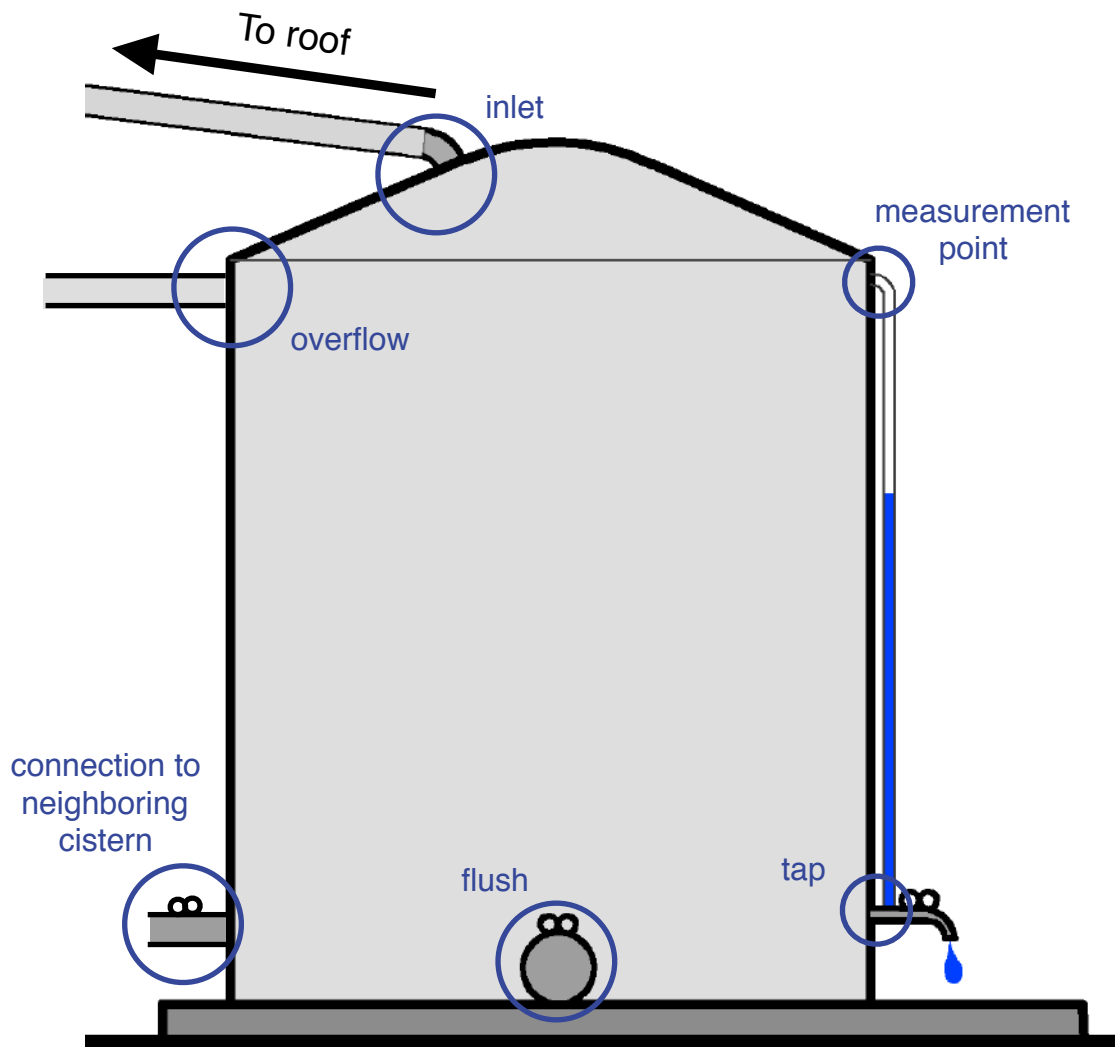


Figure 3.4 — The five fittings on a cistern

These include the inlet, where the water enters, the overflow, where extra water exits, the tap, from which the user removes stored water, the flush, used to remove waste, and the measurement point, used to attach a measurement tube.

If you intend to connect multiple cisterns in series, you can add another connection outlet on the bottom (see section 3.1.5 for details).

Structural humidity — Some materials, concrete especially, need to remain humid to avoid cracking. If you are constructing a concrete cistern, especially one that sits in direct sunlight, you should never allow it to empty completely (except for brief flushes, as described in section 3.1.4). This layer of water maintains a high level of humidity inside the cistern, decreasing the likelihood of cracking. Cement continues to cure chemically underwater, so once the inside of the cistern has begun to set (about an hour after completing the final inner coat) make sure to add water and cover to prevent cracking during the early setting phases of construction. Keeping the tap elevated prevents a user from draining the cistern completely during everyday use.

With these three considerations, you can choose a tap and decide how high above the ground to install it.

3.1.3 Overflow

When constructing your cistern, it is crucial to consider what will happen when it is completely full and you continue to put water in. That water needs to go somewhere! Depending on your cistern design, adding excess water could lead to:

1. Water touching the top of the cistern. Many cistern designs have exposed metal, rebar, or mesh on the underside of the roof. Water contact could leach rust into your water supply.
2. Putting pressure on the top of your cistern. Many cisterns have lids, doors, or patches along the roof which are weak points. Overfilling your cistern could lead to leaks along these seams.
3. Cracking the cistern. Overfilling may provide more pressure than the cistern was designed to withstand leading to bulging and/or ruptures.

Thankfully, it is simple to avoid these problems. Simply add an overflow to your design as shown in *figure 3.4*. This is a pipe, installed at the maximum level you want in your cistern, that allows excess water to exit. Overflow pipes should be:

1. As high as possible
2. Below any sensitive seams, exposed metal, or potential points of failure
3. Run to something productive like a tree or garden. Just because you can't capture the water in your cistern doesn't mean it should go to waste.

3.1.4 Flushing

As mentioned in section 3.1.2, over time, sediment tends to build up in cisterns. To get rid of this accumulated gunk, make sure to install a flush valve that is separate from your regular-use tap. As shown in *figure 3.4*, this valve should be as close to the cistern floor as possible and large enough to flush chunks of sediment. We recommend at least a 1.5" opening. Since this valve can empty your cistern completely in a few minutes, we recommend not using a standard valve with a handle, but rather anything you can find that requires a special tool to open to avoid the risk of children accidentally draining the cistern. We typically use a galvanized cap as shown in figure 3.5.

If you are connecting multiple cisterns together in parallel or series, make sure that each has its own flush valve (see section 3.1.5 for more details).

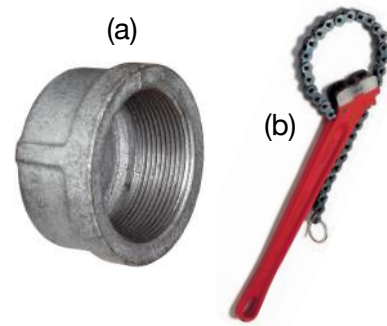


Figure 3.5 — Components of a flush valve

We usually use (a) a galvanized 2" cap on a galvanized 2"x8" nipple for our flush valves. They can be opened with (b) a chain wrench but not by hand. Make sure to close the valve with plenty of teflon tape.

3.1.5 Connecting multiple cisterns

If you want more storage capacity than a single cistern can provide or you can only afford to install a small cistern at the moment, never fear! There are many simple ways to connect cisterns together to either get extra storage or install a system piecemeal over time. When connecting cisterns, you can either link them in parallel or in series. Each has its advantages and disadvantages.

Parallel (figure 3.6a) — All of the cistern levels are always constant, so the levels rise and fall together. You can always close them off and use each cistern independently if necessary. You are always using the newest water which means that the oldest water may stagnate in the cistern.

Series (figure 3.6b,c) — Cisterns fill one by one and are drained independently. Depending on how you set them up, you are either getting the newest water (leading to stagnation of old water) or the older water.

Regardless of which design you choose, make sure that each cistern has an overflow (as described in section 3.1.3) and a flush valve (section 3.1.4).

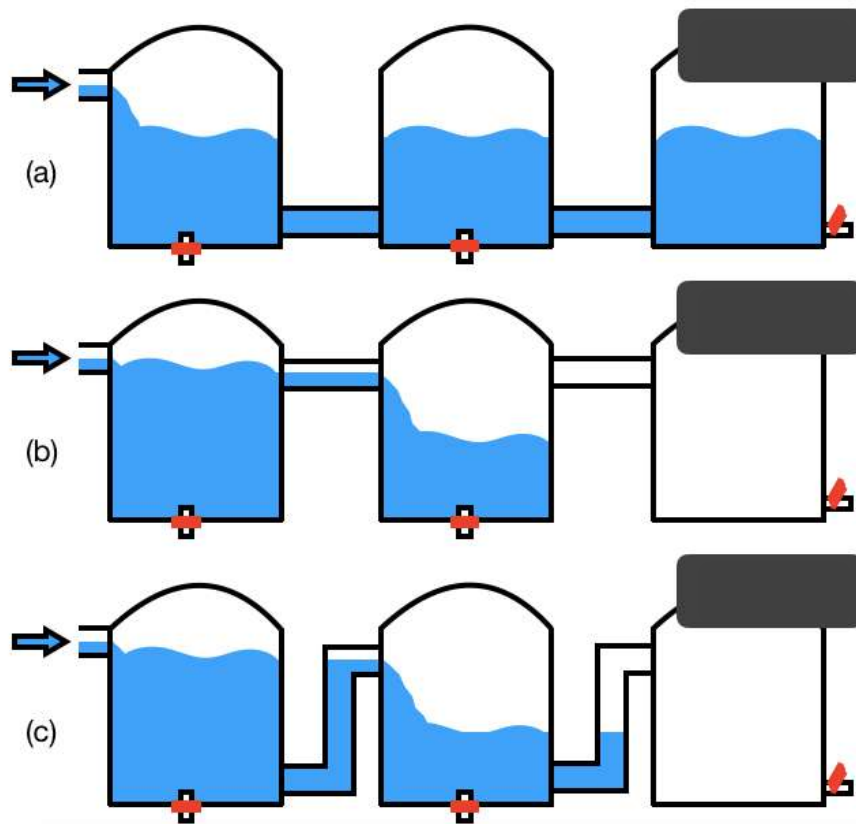


Figure 3.6 — Various Cistern Configurations

Cisterns connected in (a) parallel and (b, c) series. Note how in parallel, all three cisterns fill together. In series, the first cistern needs to fill completely before the second cistern begins to fill. In (b), the newest water flows into the second cistern and turbulently mixes as it falls in. In (c), the oldest water flows into the second cistern with less mixing.

It is hard to cut new holes or make any modifications to a cistern once it is full of water. If you intend to connect multiple cisterns together, *make a plan from the start!* That way, you can add the appropriate holes, fittings, tubes, and valves (as shown in figure 3.4) to your first cistern. You can then add another cistern easily whenever it is available. Planning your system can take a bit longer at the beginning but can save you a huge headache (and perhaps thousands of liters of wasted water) later on.

3.1.6 Air

If your cistern is completely airtight, then as you put more water in, you will compress the air, creating pressure. This will (a) only allow your cistern to fill 20-30% and (b) increase the risk of cracks and leaks in unexpected locations. Therefore, it's crucial that air can move through the top of your cistern. This is often trivial. An overflow pipe, your water inlet, or a maintenance hatch can double as an airflow. Plastic, fiberglass, and other prefabricated cisterns often come designed with an airflow.

3.1.7 Mesh screens

If there are any gaps through which insects, small animals, bird poop, etc. can enter the cistern, make sure they are covered by mesh. We use fine plastic or fiberglass meshes, purchased from a local hardware store, but any plastic mesh small enough to keep out insects should work. For more information on mesh screens, see chapter 5.

3.2 Building a 12,000 liter ferrocement cistern

Although you could purchase a plastic cistern, dig an underground cistern, or use any variety of reinforced concrete to build a cistern, this manual goes through the step-by-step process of building a **12,000 liter**, freestanding, ferrocement cistern (figure 3.7).

This section is divided into seven construction stages:

- 3.2.1 Welding preparation
- 3.2.2 Tools & materials
- 3.2.3 Reinforcement
- 3.2.4 Cistern base
- 3.2.5 Cistern wall
- 3.2.6 Cistern roof
- 3.2.7 Finishing touches

The construction steps of this manual are organized chronologically: do the first steps first! However, it can be useful to skim through the whole chapter first and make sure to have all materials on hand before beginning construction. Additionally, consider where to build your cistern based on the guidelines in section 2.3.



Figure 3.7 — 12,000 liter ferrocement rainwater harvesting cistern, with a 200 liter first flush system and PVC connections to a cement roof.

3.2.1 Welding preparation

The following section describes two cistern components that need to be welded before constructing the cistern. Section 3.2.1.1 explains how to attach rebar to a galvanized nipple to prevent leaks when using the cistern. Section 3.2.1.2 details how to cut, drill, grind, and weld a door for the top of the cistern. Both of these require at least welding equipment, if not heavier duty metalworking equipment like an angle grinder and metal drill. With the following section, you should be able to commission a local metalworker or welder to assemble these two pieces for you. If you do not have welding experience, we highly recommend finding an experienced welder rather than attempting these parts yourself. You should not need to weld anything else in this manual. Make sure these pieces are complete before you begin any of the layers of cement.

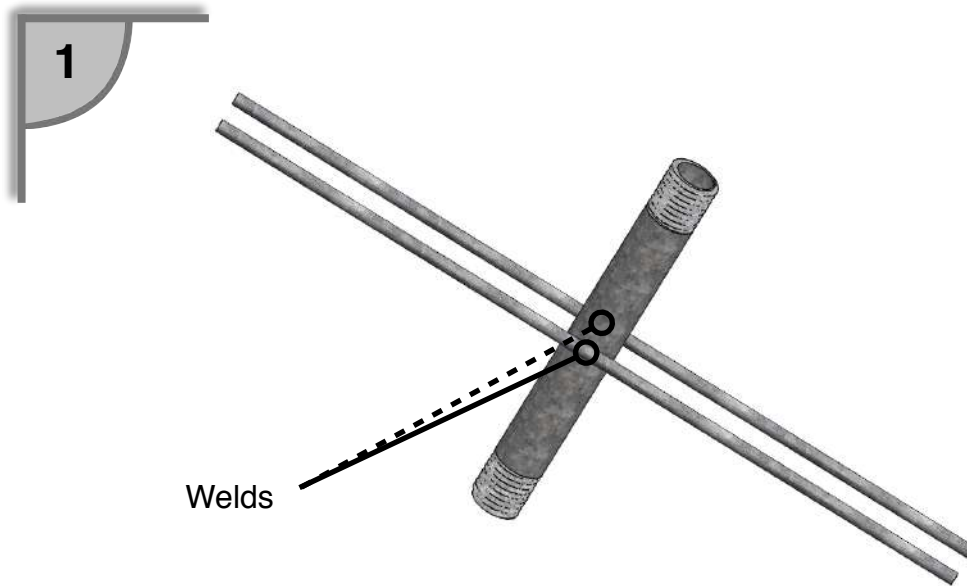
3.2.1.1 Drinking water tap nipple

Materials

4x
T1
6" - 8" long, 1/8" wide rebar (can be cut from end of rebar reinforcement roll)

2x
T2
1/2" x 4" galvanized nipple (see M16)

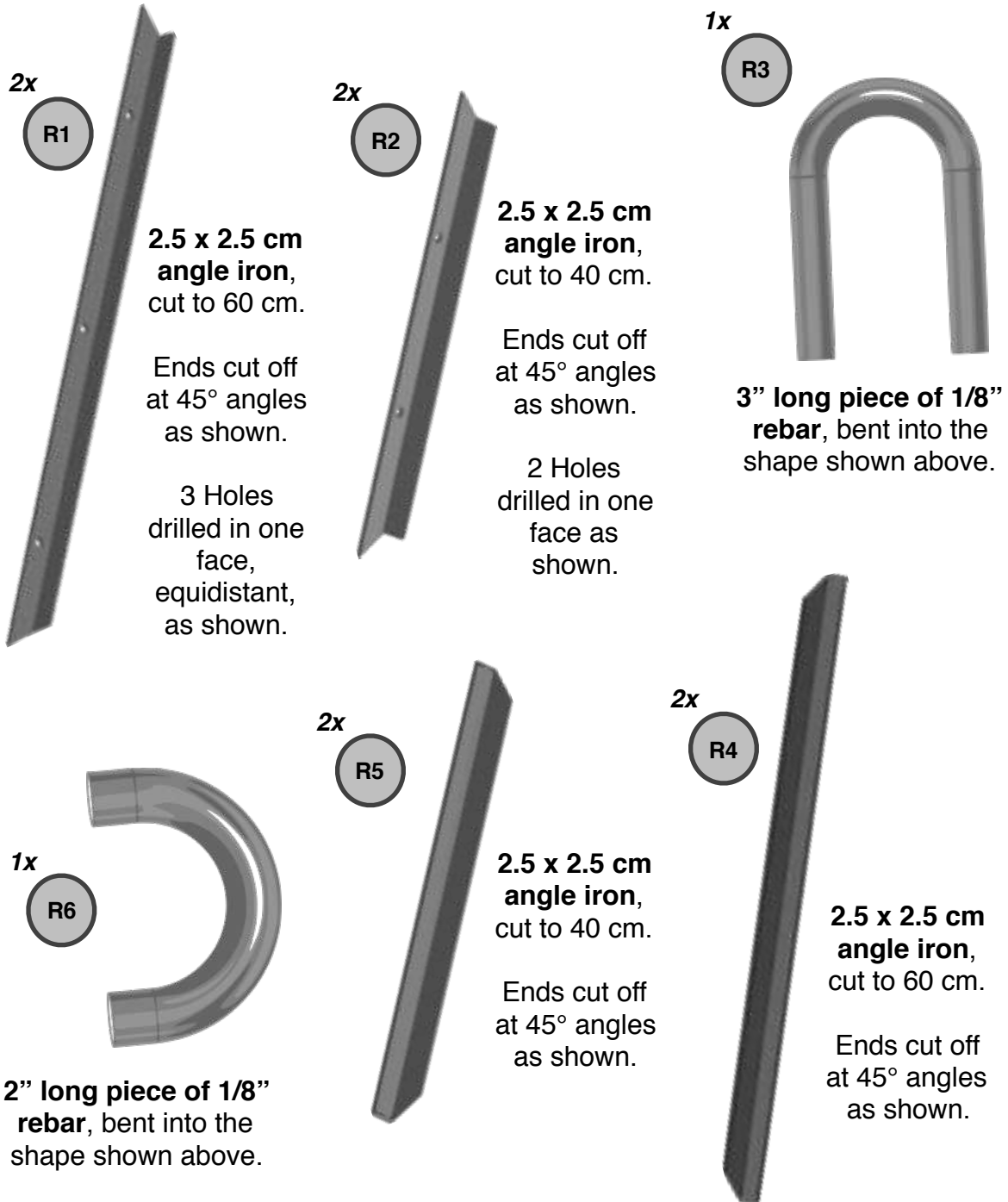
Steps



Holding the rebar (T1) on either side of the nipple (T2) as shown, weld the three pieces together. Repeat to make two of these pieces. That's it, done!
(You will use both pieces in section 3.2.5.2, step 4.)

3.2.1.2 Cistern roof door

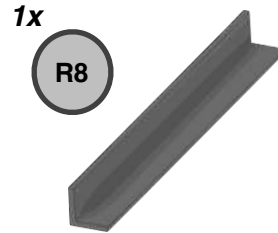
Materials



Materials (continued)



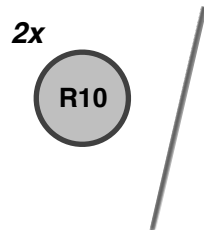
2-3mm thick sheet metal. Cut a piece 39x59cm.



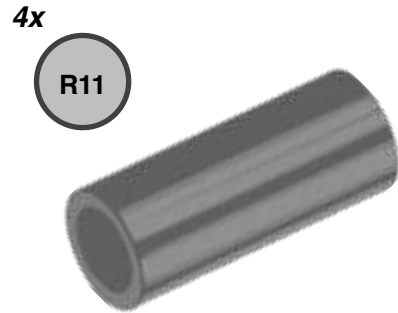
1.5 x 1.5 cm angle iron, cut to 10-15 cm in length.



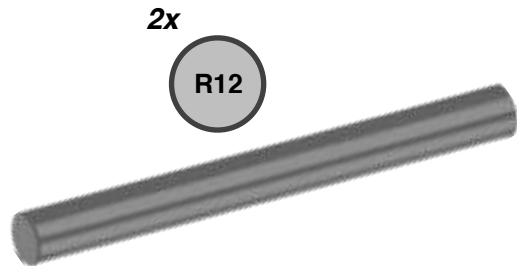
1/8" rebar, 1 meter in length.



1/8" rebar, 25 cm in length.

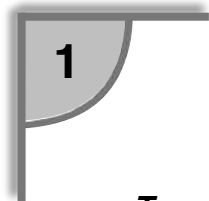


1.5 cm steel or iron tube, cut to 2.5 cm length.

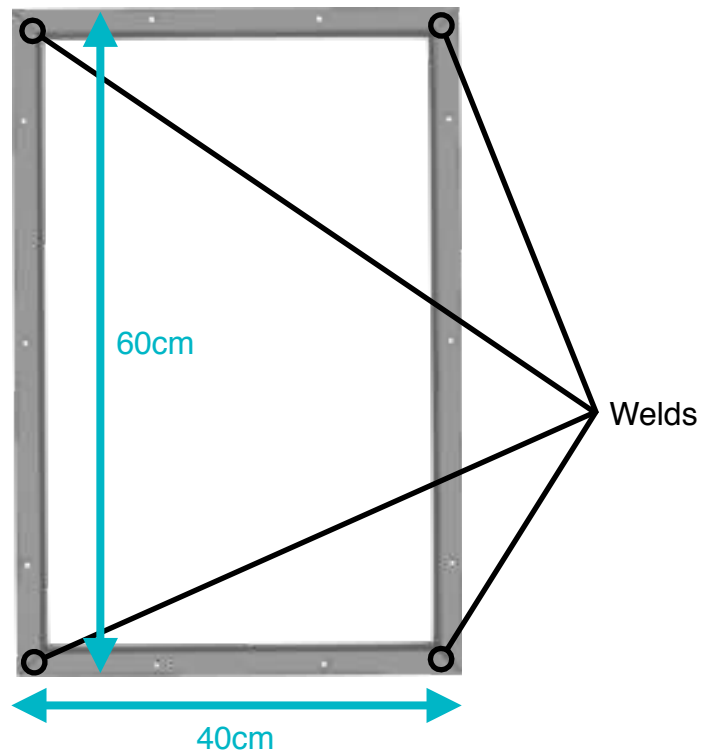


1/4" rebar, 6 cm length.

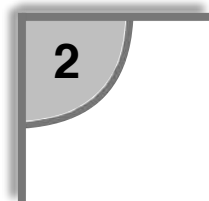
Steps



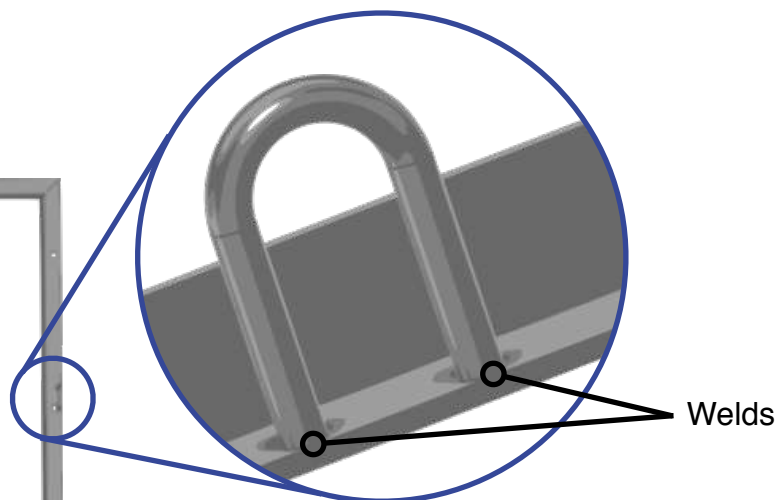
Top view



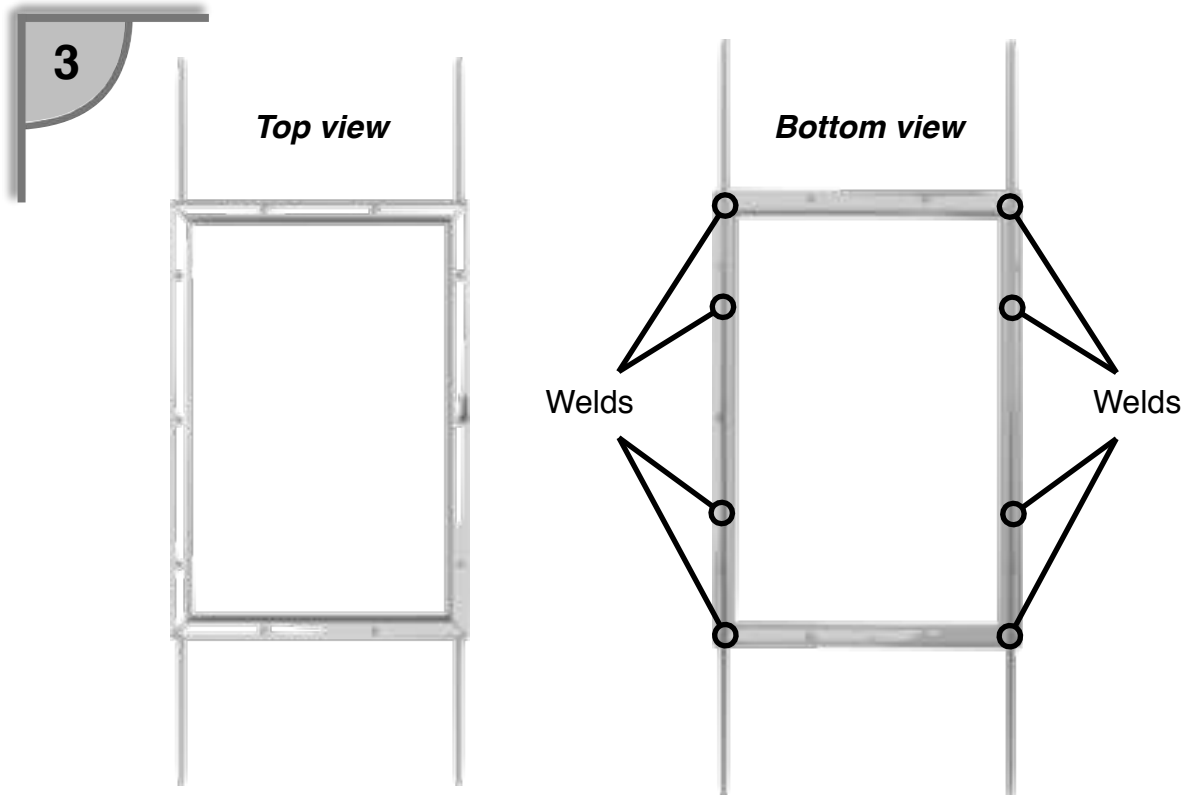
Weld bars R1 and R2 together as shown. This is the base of the door.



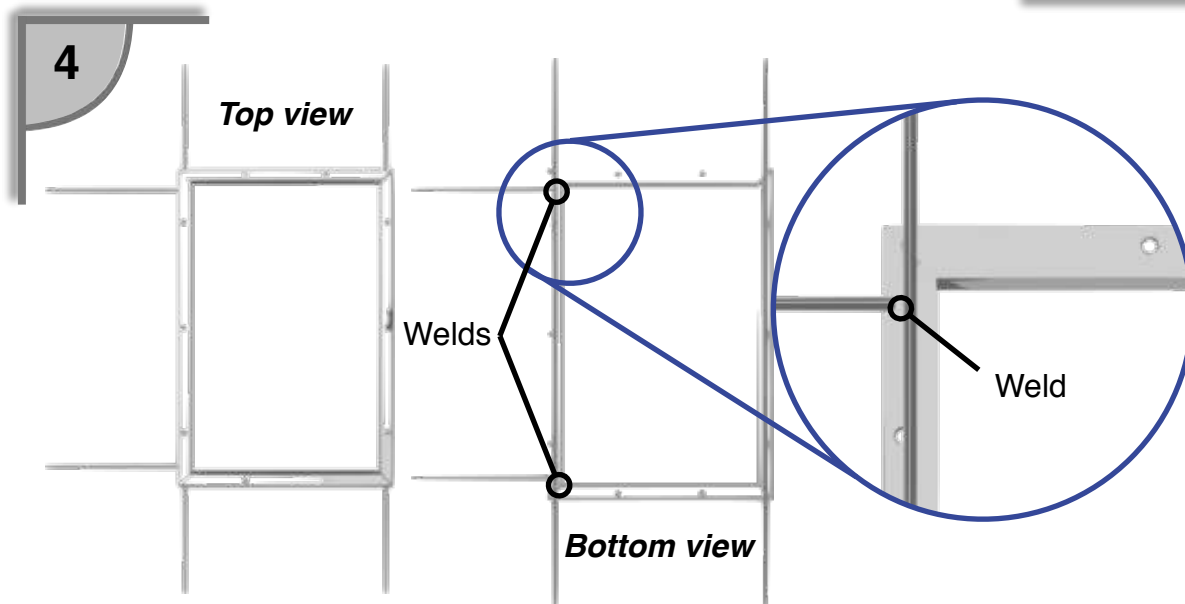
Top view



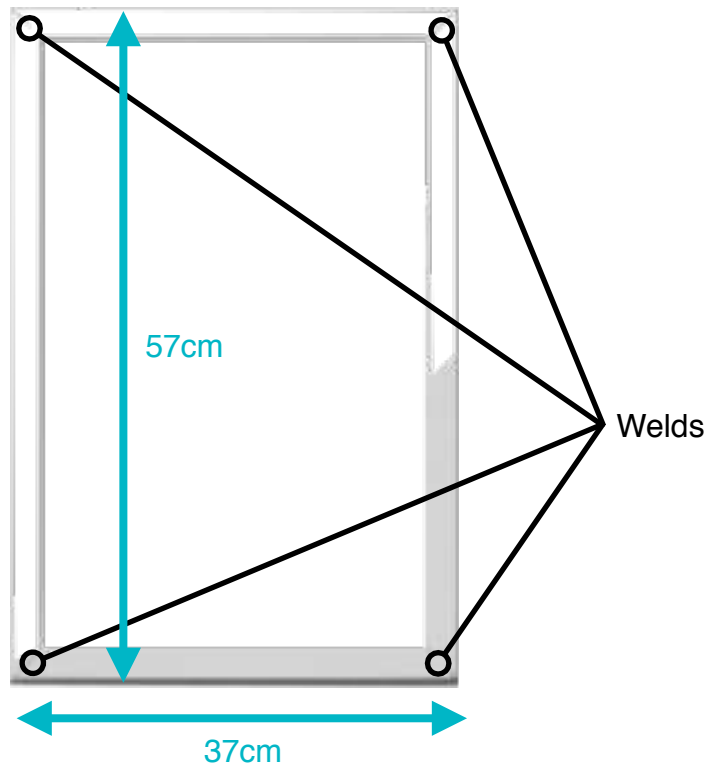
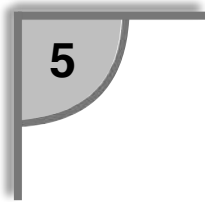
Weld R3 onto the surface of R1 with the holes, roughly equidistant from either end.



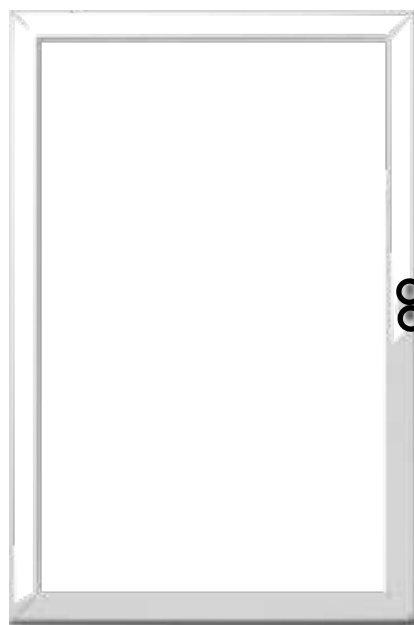
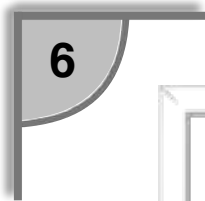
Weld the 1 meter rebar (R9) along the bottom of the R1 pieces, lengthwise, with 4 or 5 tack welds. Make sure about 20 cm extend on either side. Do not cover the holes!



Weld the 20 centimeter rebar (R10) to the edge of the bottom of the R1 pieces as shown. Make sure these weld beads are as long as possible. Do not cover the holes! Now the base is complete, next we'll make the door.



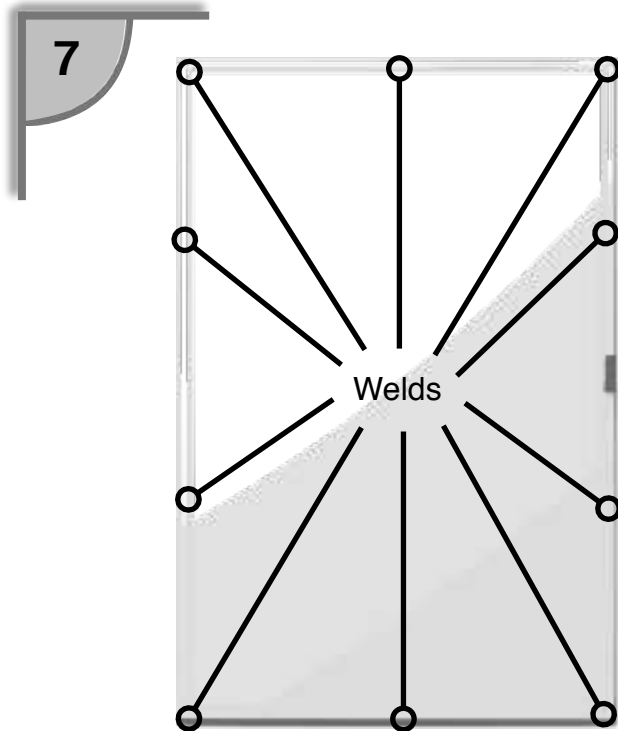
As a separate piece, weld bars R3 and R4 together as shown.
This is the door of the assembly.



Top view

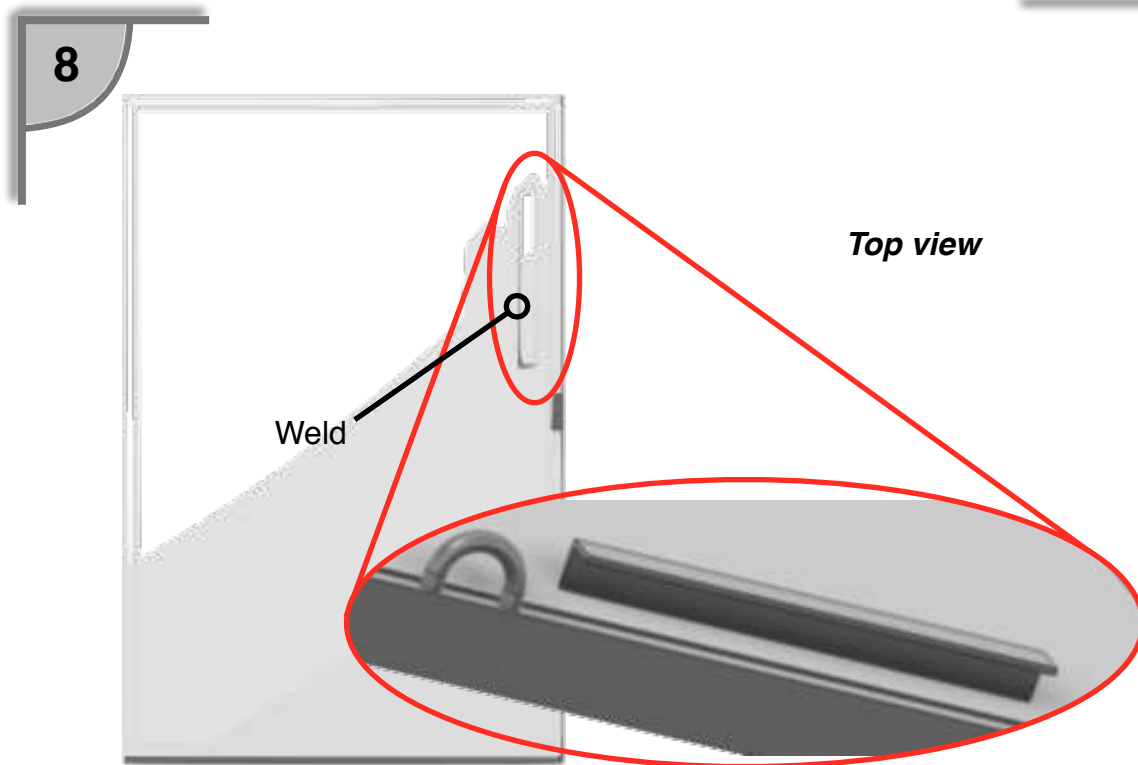
Welds

Similar to step 2, weld R6 onto one of the R4 pieces of the door. This piece needs to line up with R3 from step 2. To do so, line up the roof panel (step 5) with the base panel (step 4) before welding R6 to R4. These will be connected to lock the door.



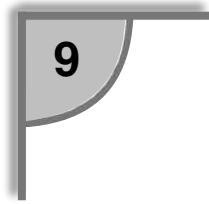
Top view

Attach the R7 sheetmetal to the top of the door piece (step 6) with 3 to 5 tack welds on each side.

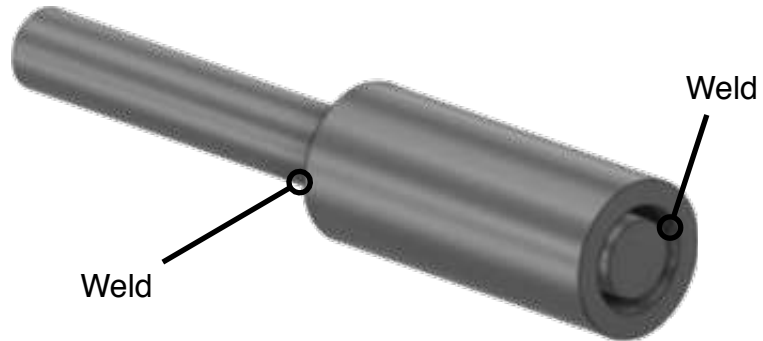


Top view

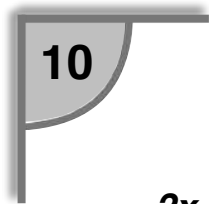
Weld the smallest piece of angle iron, R8, to the sheetmetal, R7, on the door. This will act as a handle. Now the door is complete. In the next steps, we will assemble hinges to connect the door to the base.



2x



Insert a short piece of rebar, R12, into a short tube, R11. Weld in place on both sides of the tube. Repeat this step twice.

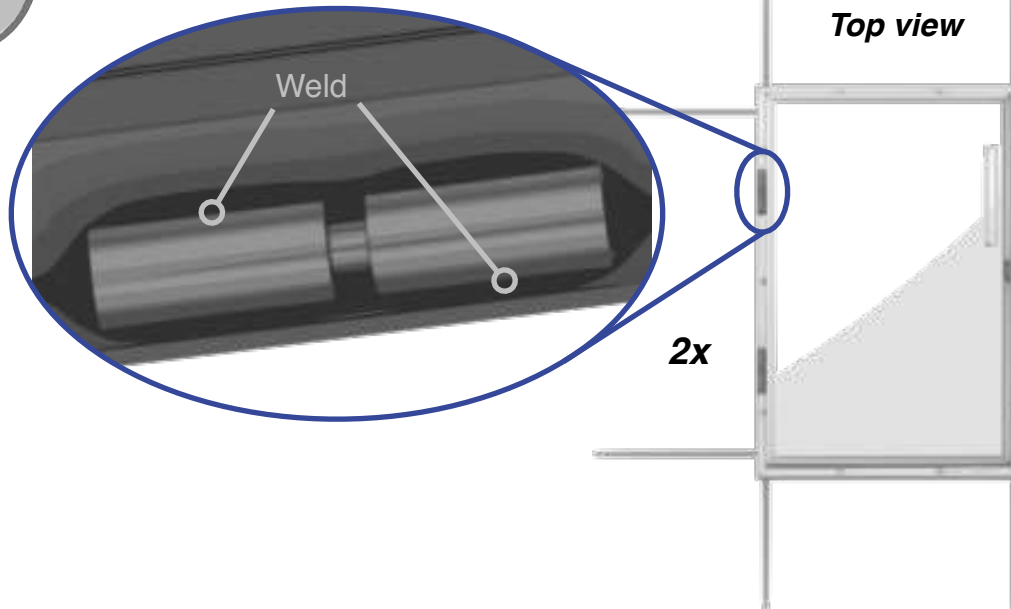


2x



Insert the other short tube, R11, onto the other end of the rebar. DO NOT WELD!
Repeat this step for both hinges.

11



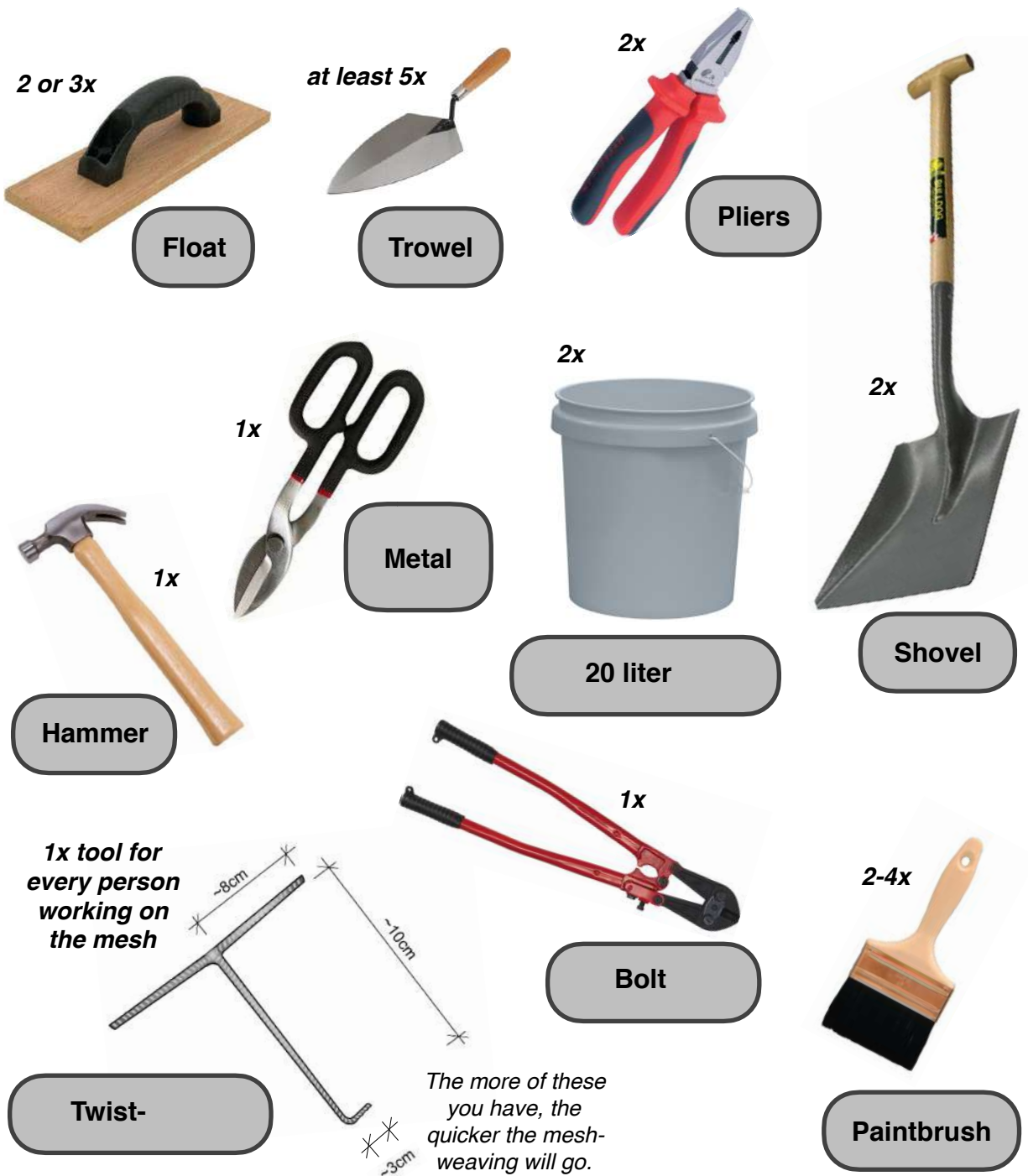
Line up the door and base, so that R3 and R6, the lock-latches, line up. Place the hinges on the opposite side from the lock-latches and handle. Do not obstruct the holes. Weld the tube that is fixed to the rebar (step 9) to the base (R1). Weld the tube that is free to rotate (step 10) to the roof (R4). This will allow the door to open, close, and be locked.

The door is complete! When you attach it to the roof in section 3.5, you do so by twisting wires through the holes in the base and threading the rebar into the cistern roof's reinforcement mesh. Time to start building the cistern!

3.2.2 Tools & materials

Make sure to acquire all the tools and materials listed in the next section before beginning construction.

3.2.2.1 Tools



3.2.2.2 Materials

Image	Material	Unit	Quantity
M1	Welded rebar reinforcement roll, with 6"x6" squares	meter(s)	15
M2	Chicken wire, 20 caliber, 1.5 meters wide	meter(s)	30
M3	Chicken wire, 20 caliber, 1 meter wide	meter(s)	30
M4	Annealed wire	kilogram(s)	5
M5	Cement	ton(s)	1
M6	Lime	25kg bag(s)	1
M7	5/8" flexible transparent hose	meter(s)	2.5
M8	3/4" flexible black hose	meter(s)	2.5
M9	1/2" hose adapter, copper or galvanized steel	piece(s)	2
M10	1/2" tap, copper or galvanized steel	piece(s)	1
M11	1/2" tee, copper or galvanized steel	piece(s)	1
M12	1/2" 90° elbow, copper or galvanized steel	piece(s)	2
M13	1" hose clamp, steel	piece(s)	2
M14	2" pipe cap, copper or galvanized steel	piece(s)	1
M15	2" x 8" pipe nipple, copper or galvanized steel	piece(s)	1
M16	1/2" x 4" pipe nipple, copper or galvanized steel	pieces(s)	2
M17	2" PVC pipe, 0.5-1 meter	piece(S)	1
M18	Sand	6m ³ truck(s)	0.5
M19	Gravel, 1-3mm diameter	wheelbarrow(s)	5
M20	Access door, painted, welded steel/iron, 60x40cm	piece(s)	1
M21	timber, 10x10cm	8' piece(s)	4
M22	plywood, 1/16" thick	4'x8' sheet(s)	6
M23	wooden blocks	piece(s)	200
M24	water	liter(s)	1500
M25	plastic tarp or sheet, large enough to cover cistern	piece(s)	1
M26	string or thin rope	meter(s)	40
M27	plastic bag	piece(s)	15



3.2.3 Reinforcement

Once you have gathered the materials and tools, you are ready to get started. The goal of this section is to make a mesh cylinder (figure 3.8), mesh base, and mesh roof that will be the cistern's structure and form. Make sure you have lots of people to build the reinforcement, it can be a time-consuming process. Ten to twenty people can get the job done in a morning.

Follow the following steps to create a flat mesh of rebar, sandwiched between chickenwire, then slice it up to create the cylinder, base, and roof.

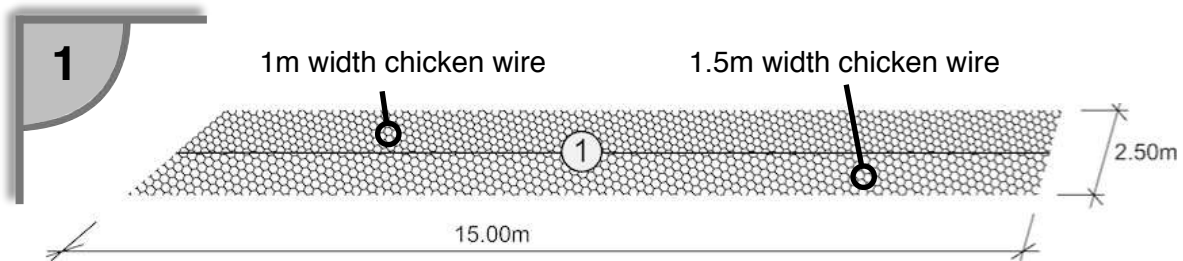
Building the reinforcement is divided up into sections:

- 3.2.3.1 Weaving the mesh
- 3.2.3.2 Cutting the mesh
- 3.2.3.3 Assembling the cylinder
- 3.2.3.4 Assembling the roof reinforcement

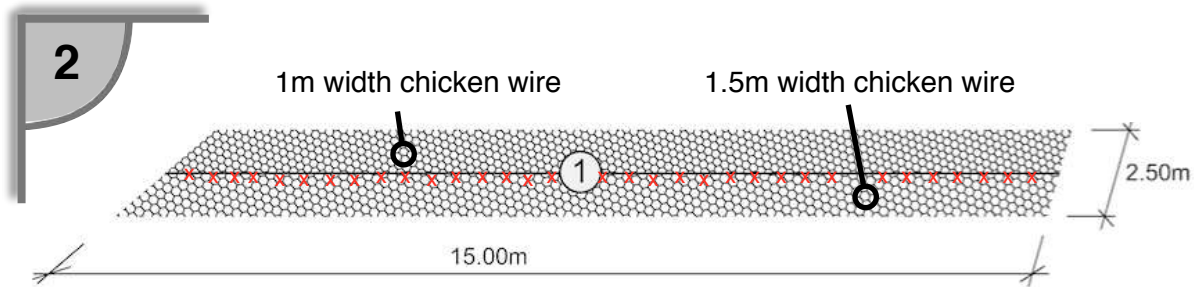


Figure 3.8 — A group constructing a cistern hold their reinforcement cylinder and base.

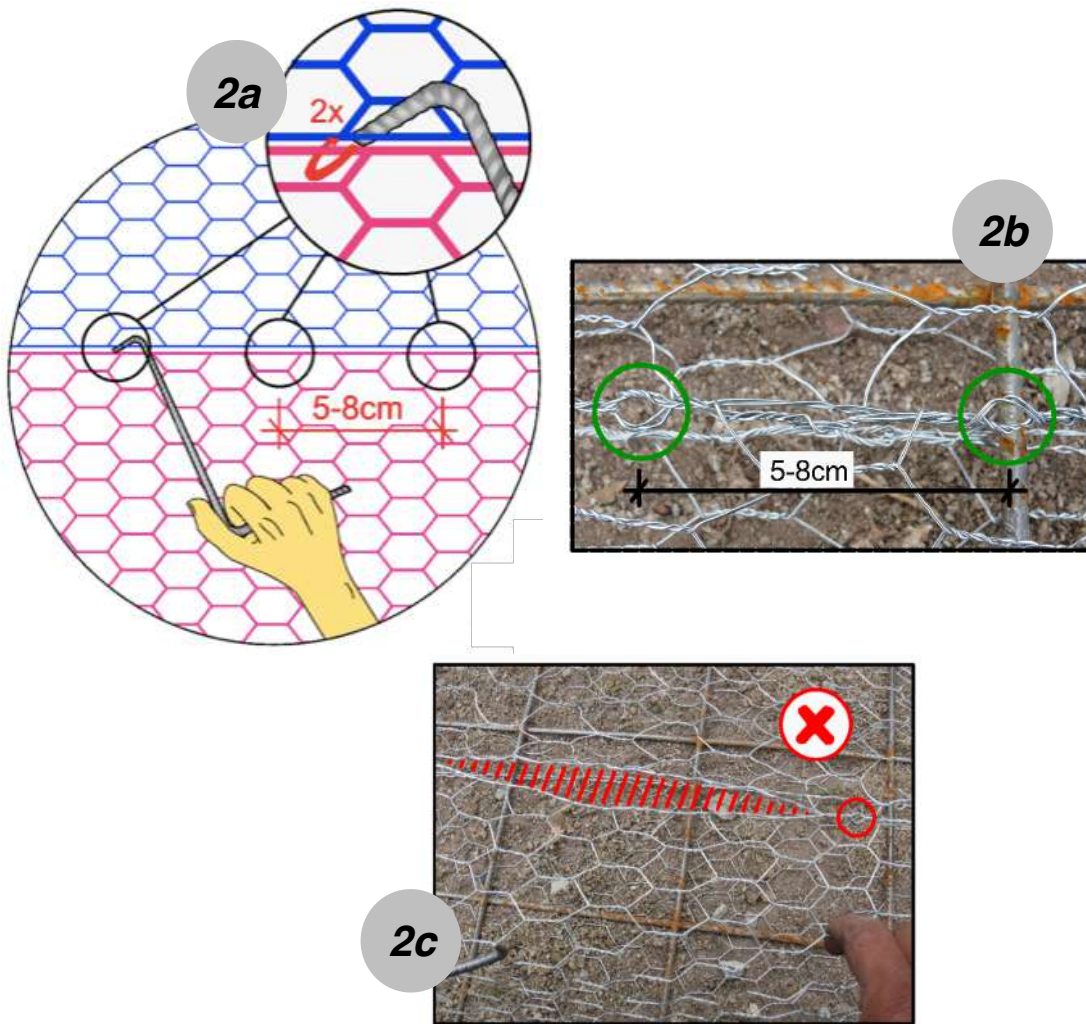
3.2.3.1 Weaving the mesh



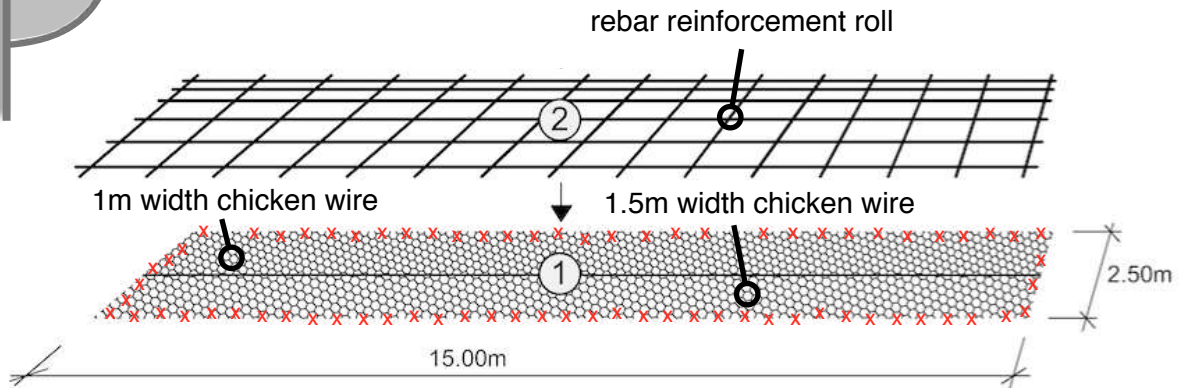
Unroll 15 meters of each chicken wire, side by side on the ground.



Using the twist grip tool (2a), twist the two chicken wire sheets together, connecting the sheets every 5-8 centimeters (2b). The chicken wire sheets should be strongly connected with no large gaps, which you should test by pulling the sheets apart from one another (2c).

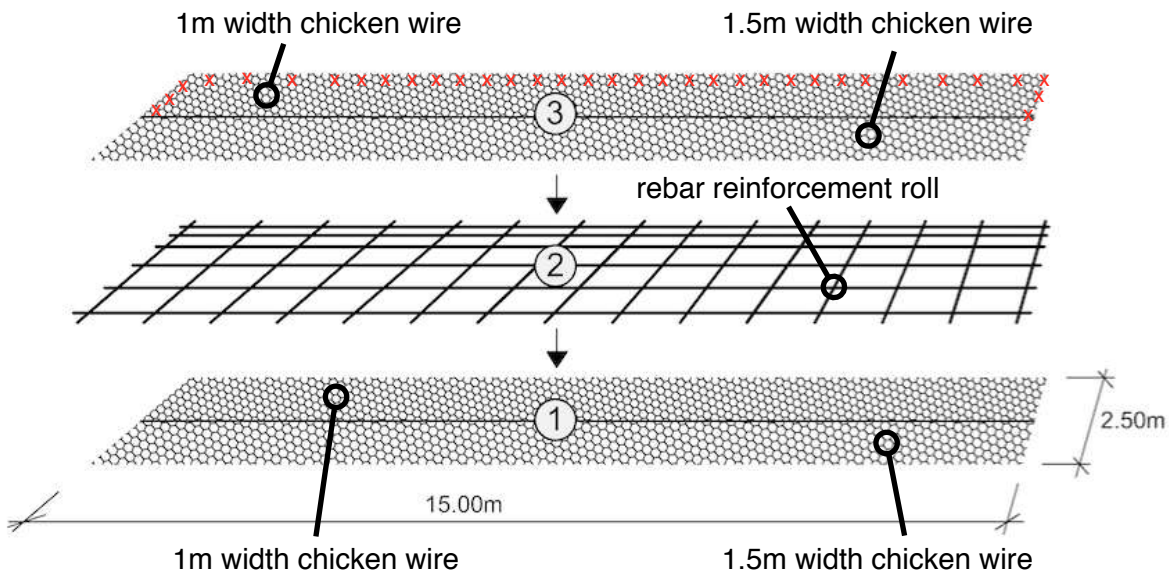


3



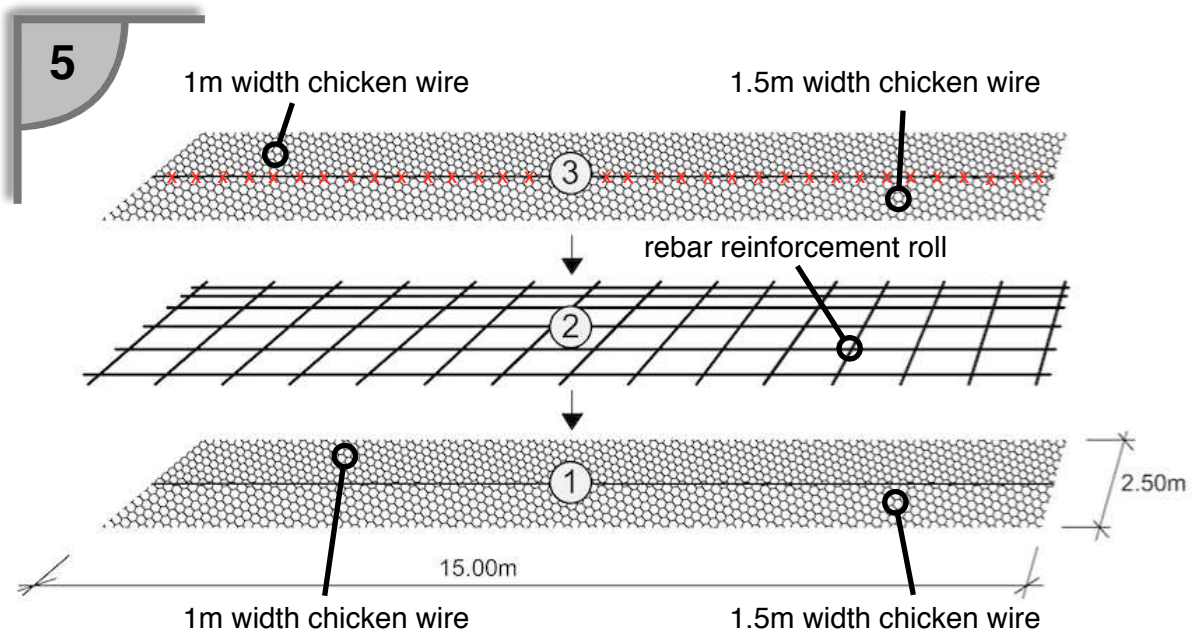
Unroll 15 meters of the 6"x6" rebar reinforcement on top of the chicken wire sheets (3a). Pull the loops of the chicken wire sheets tightly over the ends of rebar that stick out on all sides (red x's) (3b).

4

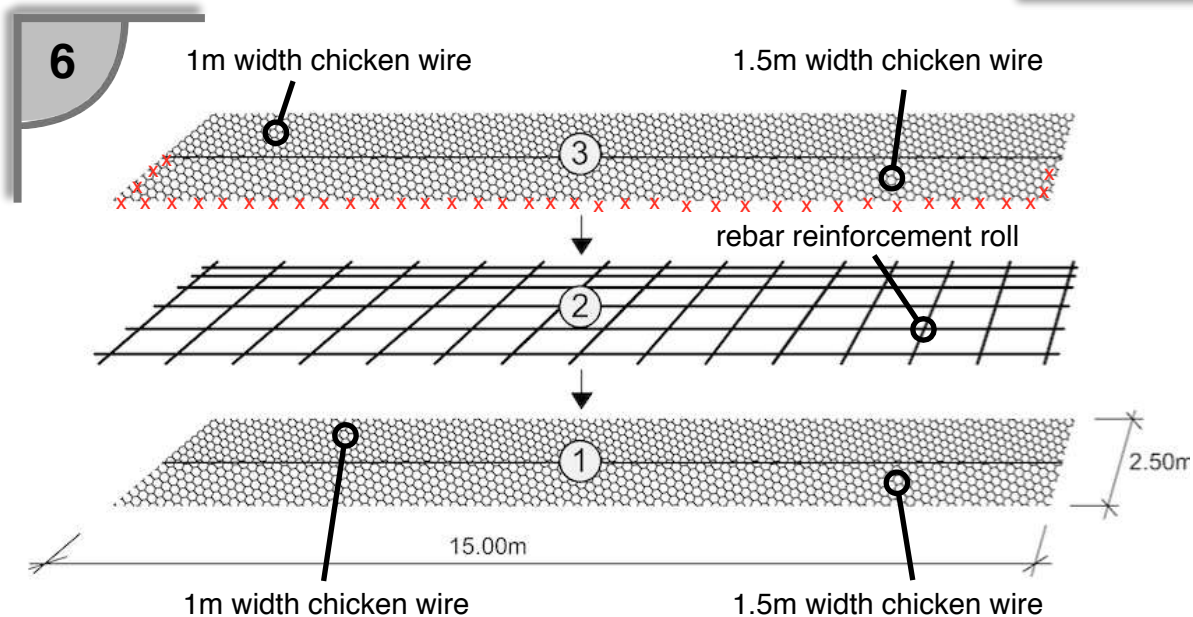


Unroll 15 more meters of each chicken wire on top of the rebar reinforcement. Pull the loops of the 1m chicken wire sheet tightly over the ends of the rebar that stick out on one side (red x's).

DO NOT PULL THE OTHER CHICKEN WIRE TIGHT YET!

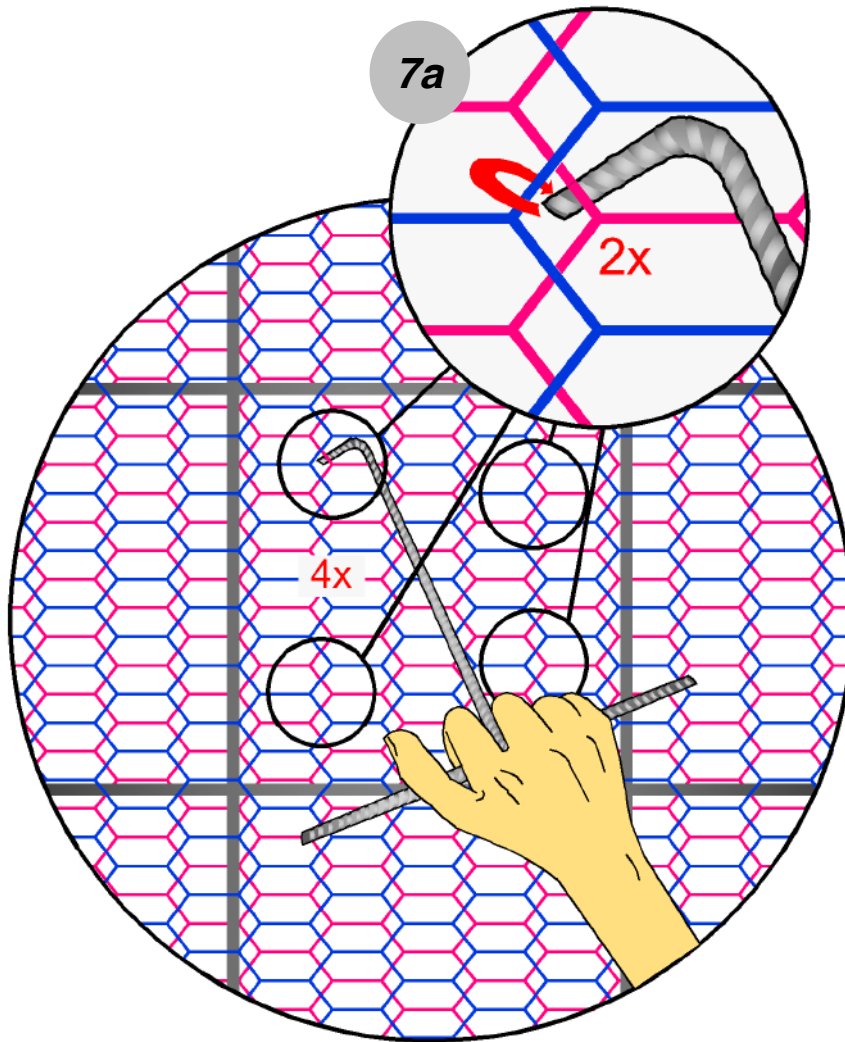


Following the same method as step (2) twist the two upper chicken wire sheets together along the red x's, connecting the sheets every 5-8 centimeters (2b). The chicken wire sheets should be strongly connected with no large gaps, which you should test by pulling the sheets apart from one another (2c).



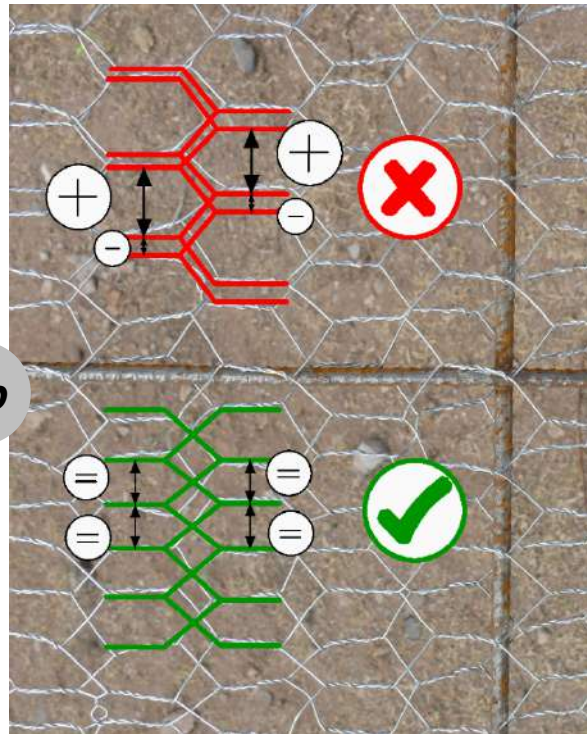
Now that the upper chicken wire sheets are connected, pull the final edge of the 1.5 meter upper chicken wire roll tightly over the rebar ends. Now all the chicken wire should be somewhat tight against the rebar.

7



Using the twist grip tool, twist the upper and lower chicken wire sheets together, securing them around the rebar. Make 4 of these twice-twisted connections in each 6"x6" rebar square (7a).

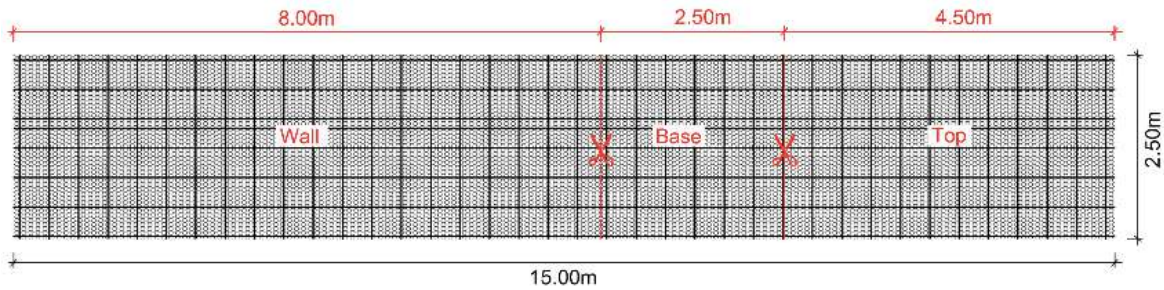
Make sure the upper and lower chicken wire sheets are *out of alignment* (7b), this creates a better surface for plastering.



Make sure to have plenty of people working together on this step (7c), with at least 10 people, you can complete the mesh in a morning.

Once you have woven the entire mesh, you are ready to cut it into pieces to assemble the cistern's base, wall, and roof. See the next section for details.

3.2.3.2 Cutting the mesh



Using the bolt cutters, cut the mesh along the red lines into three sections, with lengths 8 meters, 2.5 meters, and 4.5 meters for the wall, base, and roof respectively.

3.2.3.3 Assembling the cylinder



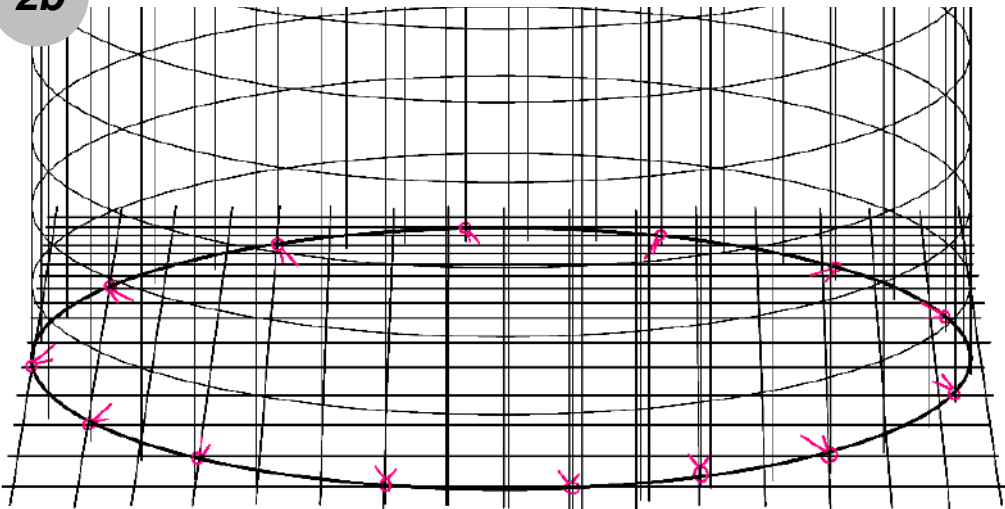
Hammer a stake into the center of the flattened area where the cistern will go. Tie 1.25 meters of wire to it. Use this setup to scratch a circle with a 2.5 meter diameter in the earth.

2

2a

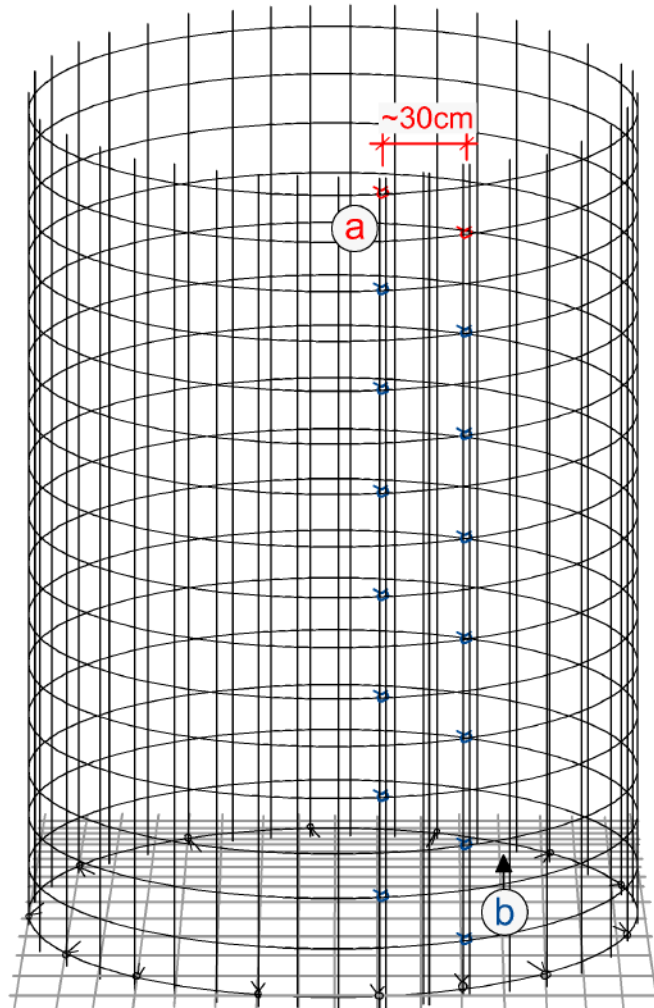


2b



Remove the stake. Place the base on the sketched circle. With a group, hold the cylinder in place with the sketched circle as a guide (2a). Fasten the cylinder to the base with 10 cm of twisted annealed wire every 12" (2b). There should be about 30 cm of overlap in your mesh (see step 3).

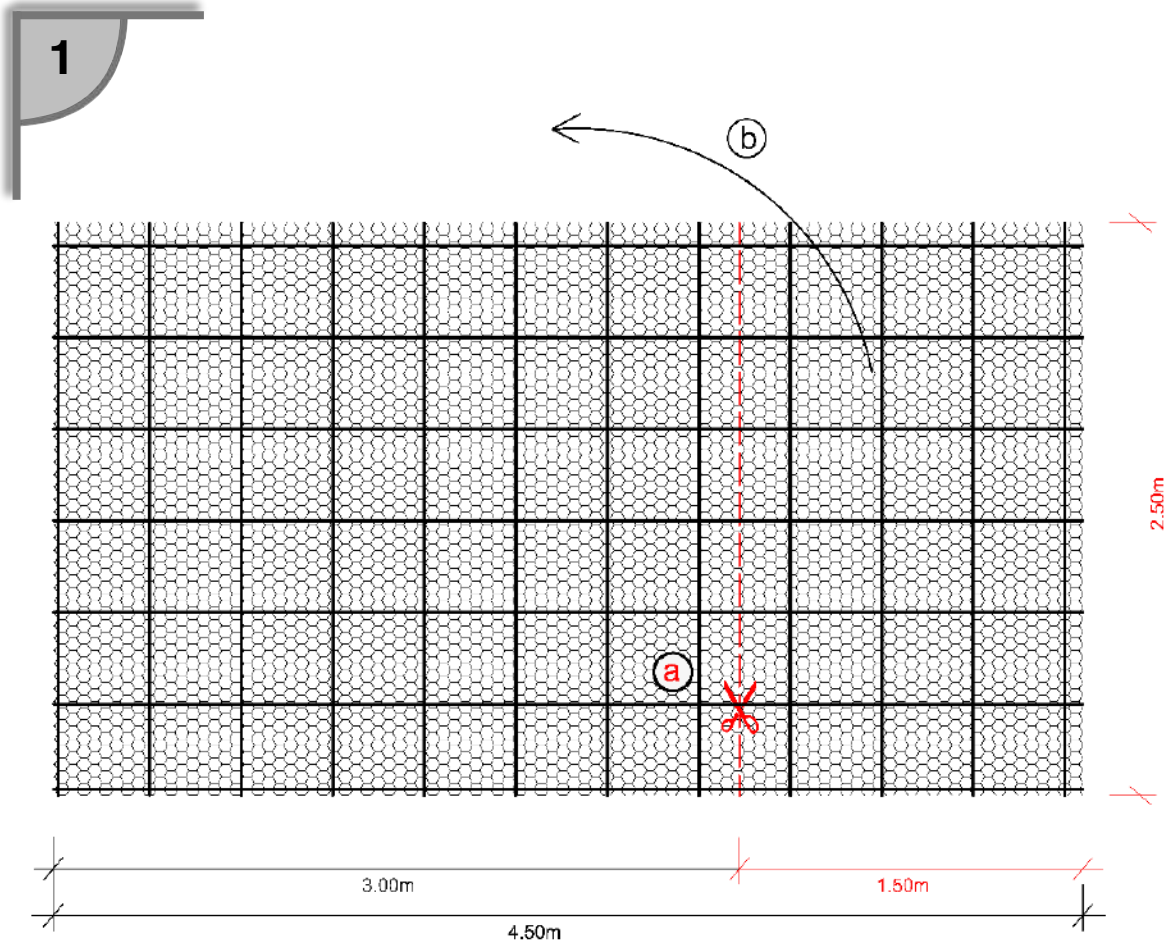
3



By twisting 10 cm lengths of annealed wire, fix the 2 ends of the mesh together. Begin at point (a) going down, connecting every 2 to 3 squares. (12" - 18"). Once that is complete, begin at point (b), going up. Make sure the cistern's width is the same at every height.

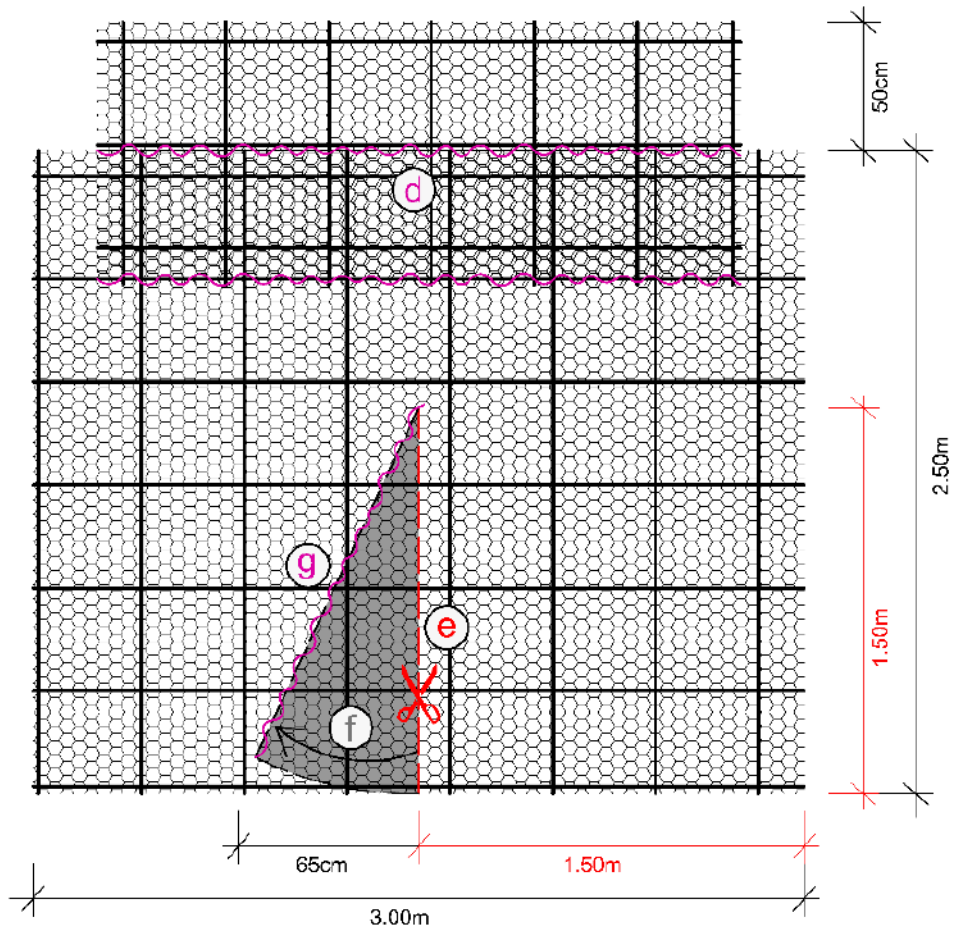
Now your cylinder is completely assembled. The next section explains how to assemble the roof reinforcement from the final piece of woven mesh.

3.2.3.4 Assembling the roof reinforcement



Cut the remaining piece of mesh along the red line.

2



Align the two pieces as shown, to get a 3x3 meter square, with two corners missing and sufficient overlap to connect both pieces. Use the twist-grip to connect the chickenwire and twist wires to fasten the rebar together.

You should now have a piece that's roughly 3 meters by 3 meters square.

Cut along the red line (e) until you reach the middle of the square.

3

Pull the mesh line (e) until it overlaps line (g). The shaded area (f) is where the mesh overlaps, making a cone.



Use 10 cm wires to connect the two sides of the mesh in the overlapping section. (follow the x's). Make sure to have plenty of wires near the mesh's edge.
Set this cone to the side, it will be used later to form the cistern's roof.

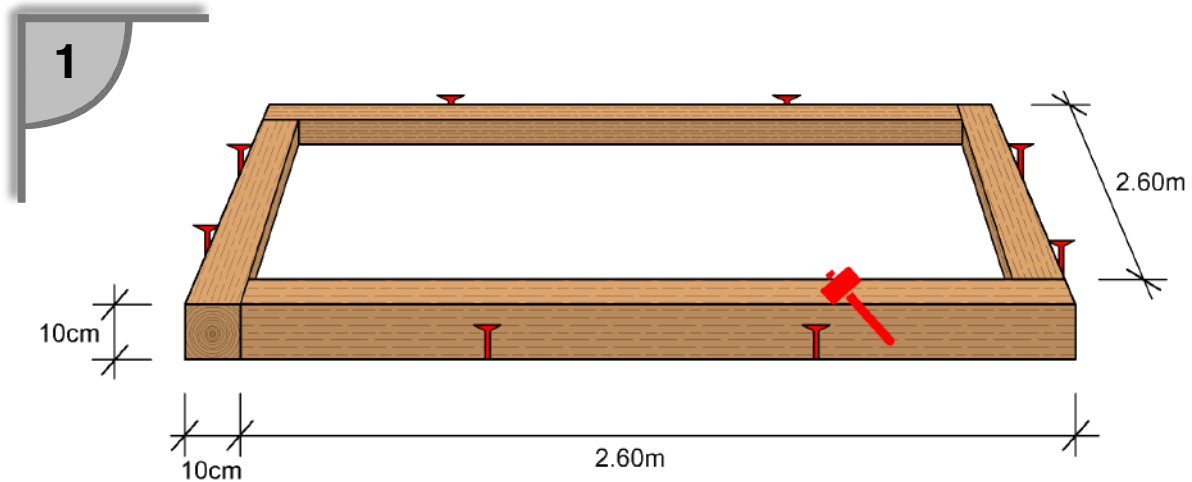
You have now completed the reinforcement mesh for the base, cylinder, and roof! The next section steps through the construction of the cistern's base.

3.2.4 Cistern base

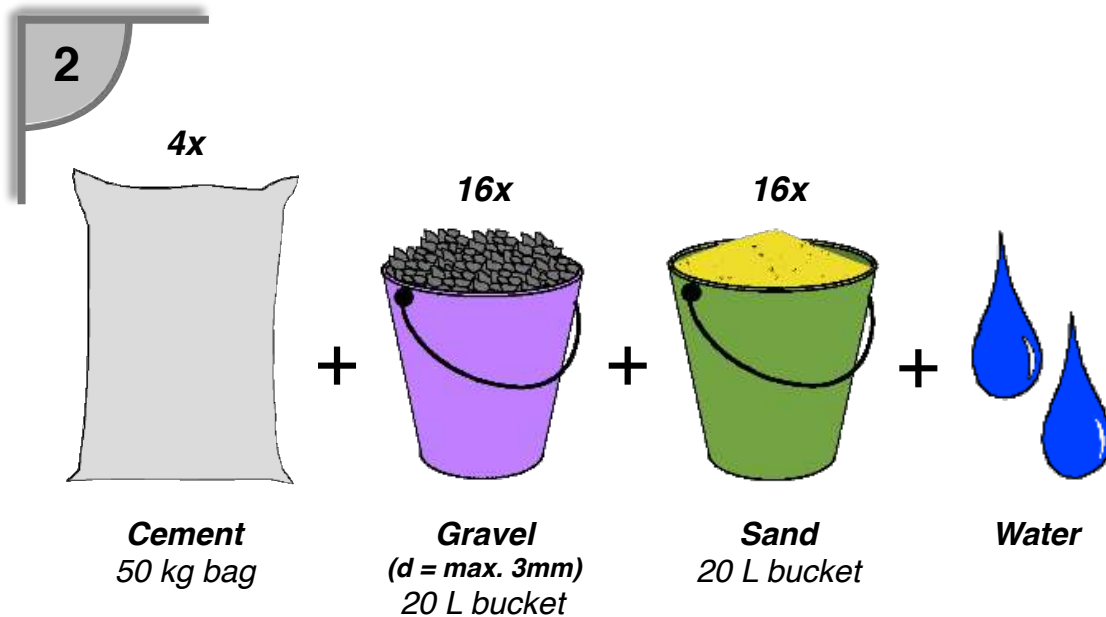
This section provides step-by-step instructions for creating a concrete base to support your cistern. When you are done with this section, your cistern ought to look similar to figure 3.9: with the reinforcement-mesh cylinder sticking up from a strong concrete base.

Figure 3.9 — The reinforcement mesh cylinder sticks up from a completed concrete base.



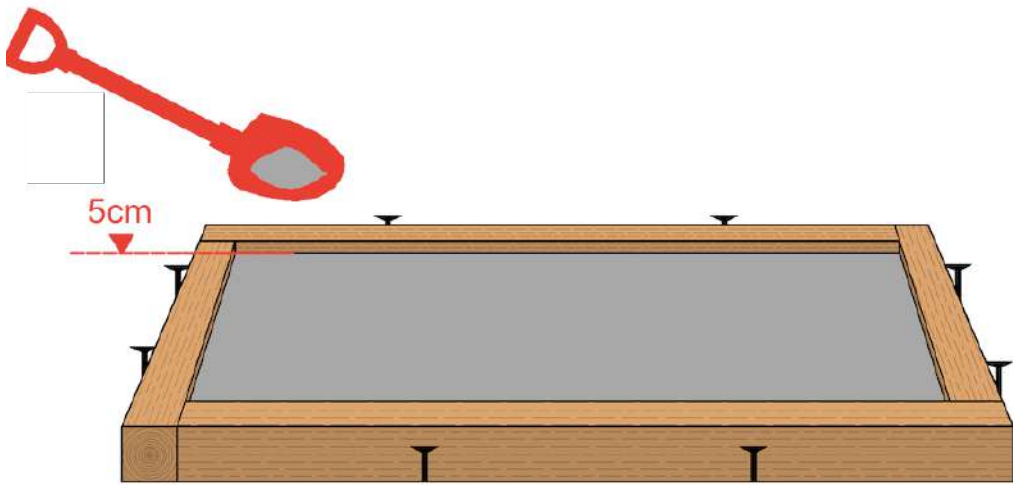


On the flattened earth where you will build your cistern, use four 10x10 cm wooden beams to construct a 2.6x2.6 meter square with a height of 10 cm as pictured. This is the formwork for your base. Hold the formwork in place with heavy nails or large rocks. *Note: you can also use bricks or stones as formwork. The base can be square or circular as long as it has a diameter of 2.6 meters (see photo in step 3).*



Mix the base concrete: 4 bags of cement, 16 buckets of cut gravel or river stones (3 cm or less), 16 buckets of sand, water. You should be able to pour this concrete mixture into the formwork.

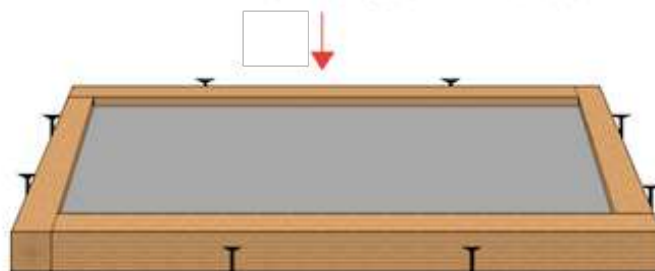
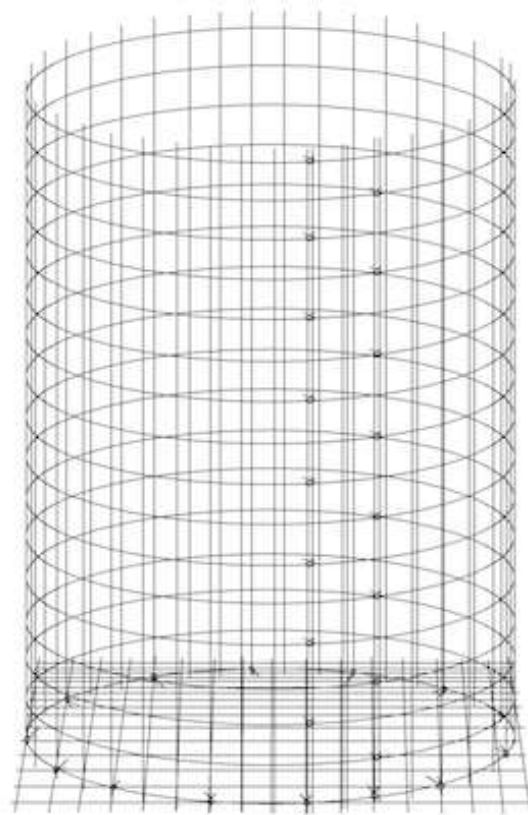
3



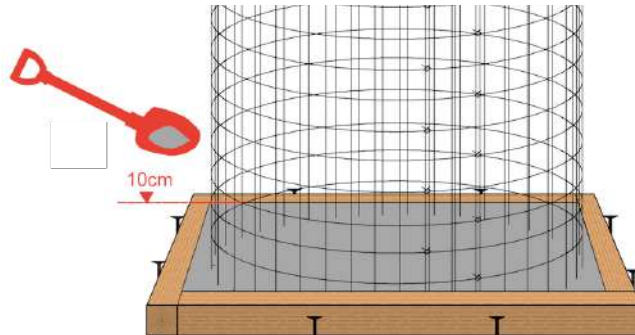
Lay 5 cm of cement into the formwork, creating the first base layer.

4

Place the cylinder/base reinforcement mesh from section 3.2.3.2 directly on top of the wet concrete. The gravel in the mix will help support the base and the layers of concrete bind better with one another when wet.



5



Lay another 5 cm of cement into the formwork, sandwiching the reinforcement mesh in cement. This should fill the formwork. For this step you will need to enter the cistern. Do so safely by using ladders as shown.

6

Hit the still-wet concrete repeatedly with a piece of wood or shovel until the surface is relatively uniform. Cover with plastic to trap moisture and keep the concrete humid.

7



ONE DAY



Let the base cure for at least one day before removing the formwork. Make sure to keep the base moist to prevent cracking. Once you've removed your formwork, your base will continue to cure.

3.2.5 Cistern wall

This section describes the process of creating the cistern's walls. The walls are made by applying repeated layers of concrete on both the inside and outside of the mesh. This section is divided up into two parts:

3.2.5.1 Attaching the formwork

3.2.5.2 Applying concrete layers

At the end of this section, your cistern should look like the one shown in figure 3.10.



Figure 3.10 — An in-process cistern with completed wall and base.

3.2.5.1 Attaching the formwork

The formwork is made from full sheets (4'x8') of plywood or fiberboard, held tightly to the inside of the mesh with wire and pieces of scrap wood. Once the formwork is attached, you are ready to begin applying concrete layers and your cistern should appear like that in figure 3.11.

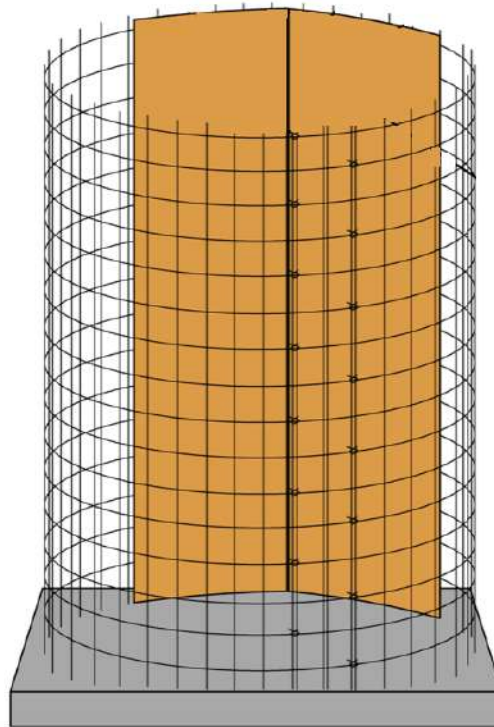


Figure 3.11 — An in-process cistern with completed base has almost all of its formwork attached. The same cistern is shown from the (a) outside and (b) inside.

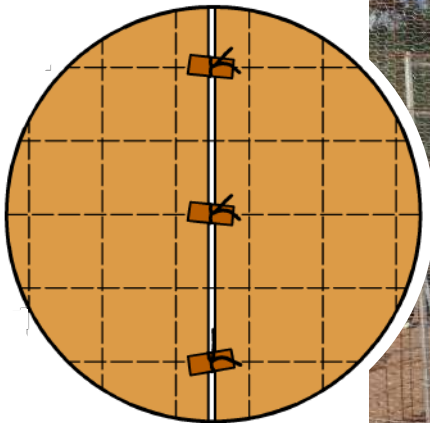
1



Insert the six sheets of plywood into the cistern vertically. It is typical to have a gap of about 10-40 cm left uncovered (shown in figure 3.11a). You can fill the gap with extra plywood, fiberboard, or scrap cardboard.

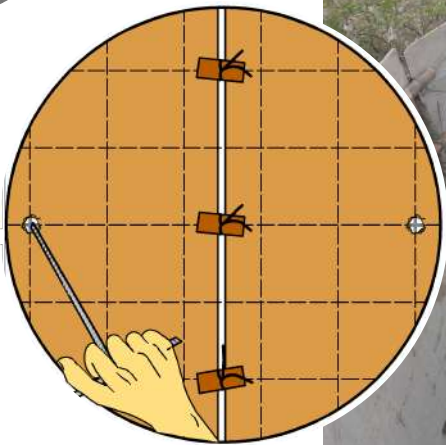


2



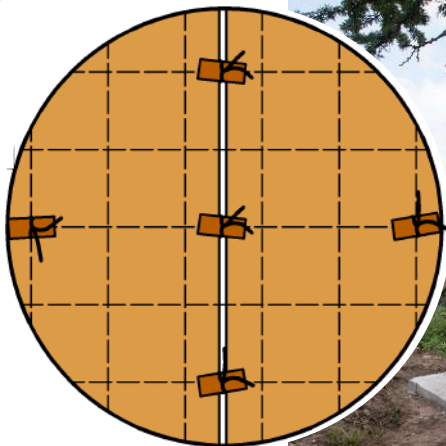
Use 10 cm pieces of wire and wooden blocks to hold the plywood sheets in place. Every two squares of rebar, thread a bent wire between the two sheets, so both ends of wire are pointing into the cistern. Place a wooden block between the ends of wire and twist the wire 3 times to fasten. The wood should be pulled tightly up against the plywood sheets, fastening them in place against the mesh.

3



Every 2 vertical and horizontal squares of rebar, use the twist-grip tool to make a hole in the wood. Do this for the plywood and the cardboard mentioned in step 1.

4

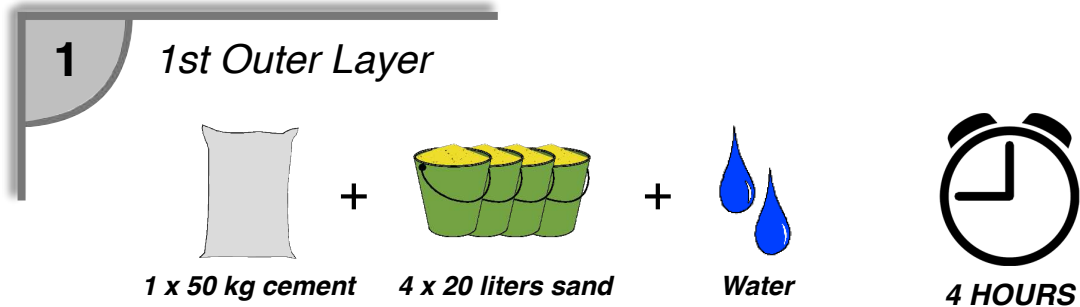


From the outside, feed a bent 10 cm piece of wire through each of these holes, so each end is going into the cistern. Wrap the ends three times tightly around a piece of wood to fasten (see figure 3.11b). This should pull the plywood tightly against the reinforcement mesh. Now you are ready to begin applying concrete!

3.2.5.2 Applying concrete layers

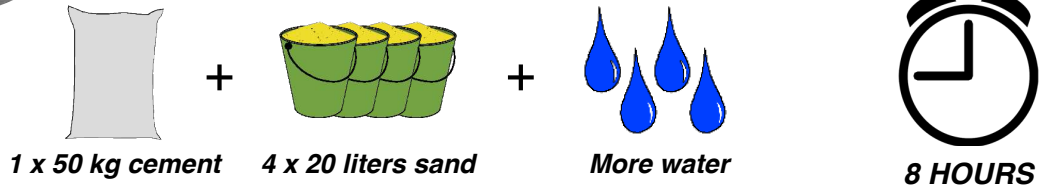
The wall is made from eight thin layer of concrete, applied one after another. The following steps indicate the ratio of cement, sand, water, and sometimes gravel in each layer, the consistency of the mixture, the thickness of the layer, and the time required to wait before applying the next layer. Make sure to keep your cistern moist during and after construction to avoid cracking. Concrete can take more than a month to fully cure!

In this section you will also remove the formwork applied in section 3.2.5.1 and install the pipe fittings and connections to get water in and out of your cistern.



For the 1st outer layer, mix one 50 kg bag of cement with four 20 liter buckets of sand. Add water. The consistency should be like thick shampoo - the concrete should stick easily in the chickenwire. Plaster the entire exterior of the cistern, stopping 5-10 cm from the top (this exposed rebar at the top will be used later to attach the roof). Wait a few hours before applying the next layer.

2 2nd Outer Layer

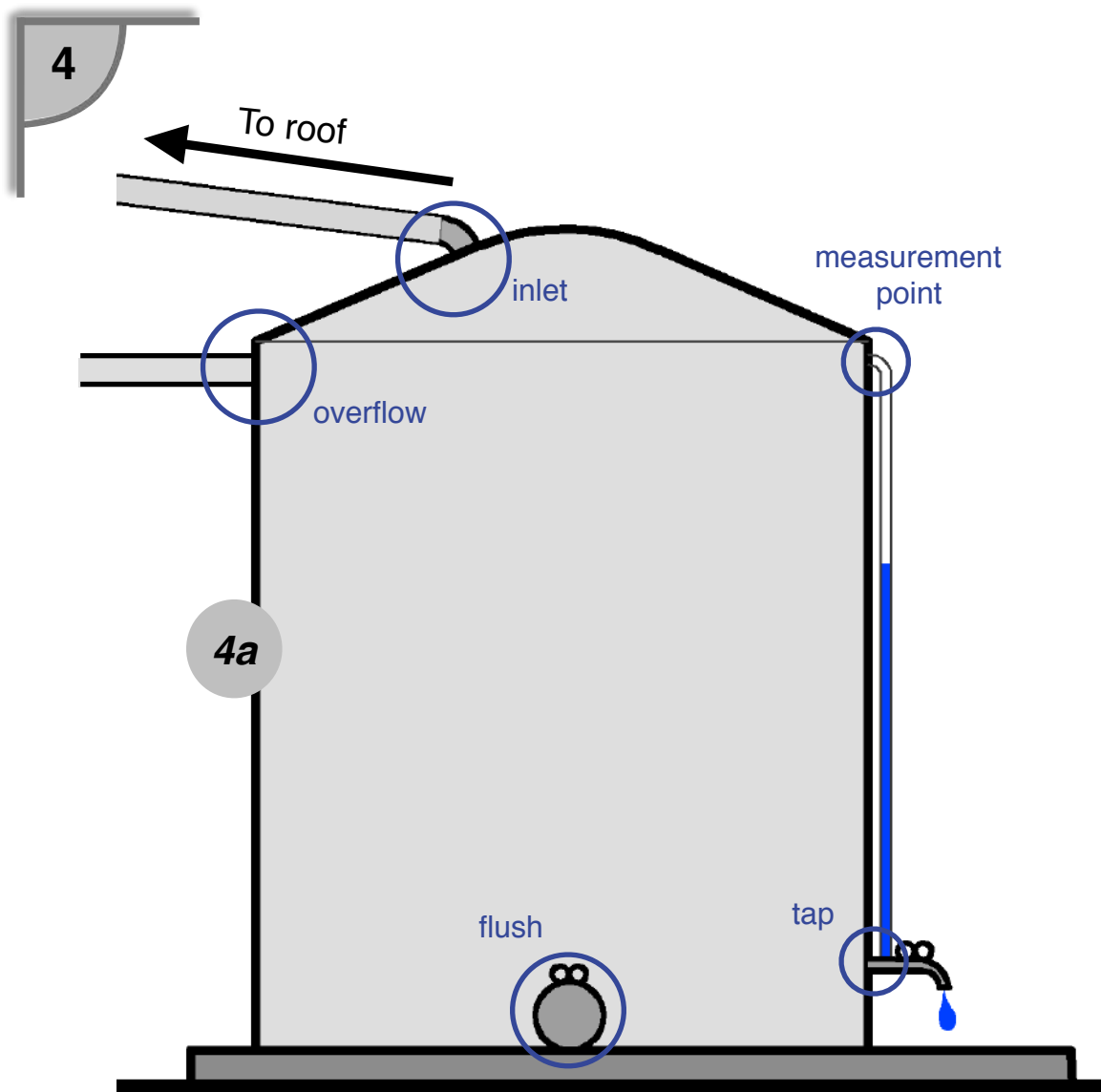


Add more water to the mixture from step 1, so that the consistency is grainier. Slap the mixture to the surface so it is rough. Make sure to fill all the cracks from the previous layer. Wait at least 8 hours before removing the formwork.

3



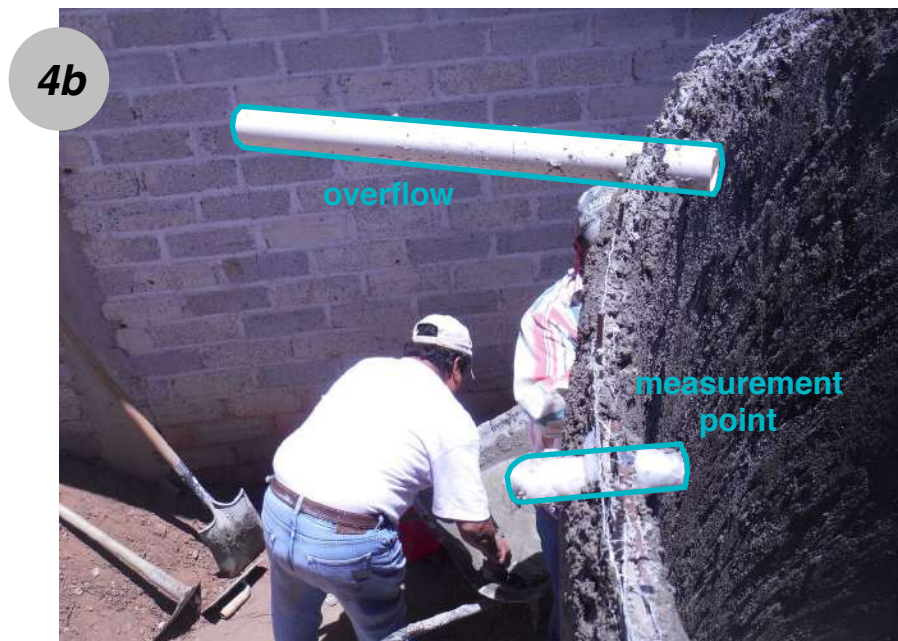
After waiting 8 hours for the 2nd outer layer to dry, remove the formwork including the plywood sheets, wood blocks, and wires.



Now that you have a thin cement cylinder with 2 layers of concrete and no formwork, it is time to insert the attachment pipes. There are five connections necessary, pictured in the drawing (4a) above: overflow pipe, inlet pipe, measurement point elbow, flush valve, and tap for drinking water. Since the inlet pipe goes directly into the roof, we will not deal with it here. Step 4, continued on the next pages, details how to make all the other four attachments.

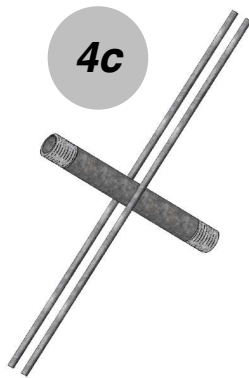
Installing the *measurement point*

Wrap the ends of a 1/2" wide x 4" long galvanized pipe nipple (section 3.2.1.1) with plastic bags and stuff a plastic bag inside to protect the nipple from wet concrete. Shove the plastic-wrapped nipple through the chickenwire and concrete at the same level as the overflow pipe. If necessary, gently create a hole with chisel and hammer. Tie rebar in place with wire. As you add concrete, the nipple will be held in place more strongly.



Installing the *overflow pipe*

Use a piece of 2" PVC that is at least 30 cm long. Cut a 2" hole in the chickenwire with the shears, 1 or 2 cm from the top of the concrete and remove the cement inside the hole. Insert the PVC pipe with 3-4" extending into the cistern. Fasten in place with wire. With each new layer of concrete, the pipe will be increasingly rigidly fixed. Make sure to fill the gaps around the pipe with concrete.



4c



4d

Installing the *tap for drinking water*

Using the welded nipple from section 3.2.1.1, wrap both ends in plastic as described in (4b). Shove through the chickenwire and concrete from the inside, until the two pieces of rebar hit the mesh reinforcement (4d). Make sure your tap is tall enough to get a container underneath! (4e). Fasten the rebar tightly to the reinforcement with wire at at least 4 points - 2 are shown in (4d). Continue to seal between the reinforcement and the nipple with each successive layer of concrete.

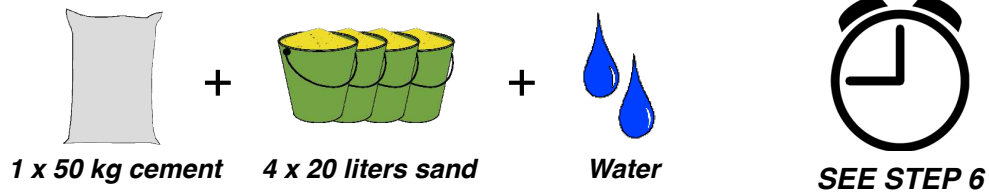


4e

Installing the *flush valve* (not pictured)

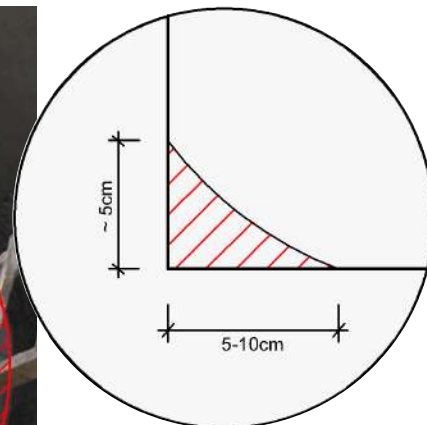
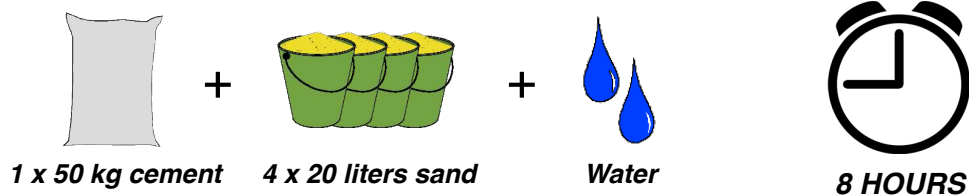
Wrap the 2" x 8" galvanized pipe nipple in plastic, the same way described for the measurement point. Using the shears, cut a 2" hole in the chickenwire at the bottom edge where the cylinder meets the base. Dig out 1-2 cm of the base to create a slope that angles down from inside to out. Insert the 8" long nipple through the hole so it is angled slightly downwards. Inside, make sure the bottom edge of the nipple is against the cistern's base. If necessary, fix in place with wire. As you add more concrete, the nipple will become more secure.

5 3rd Outer Layer



Use the same concrete mixture as in step 1. Apply a 1-1.5 cm thick layer to the outside of the cistern. Make sure to fill all gaps around the pipes you fitted in step 4. This step and step 6 can be completed *simultaneously*.

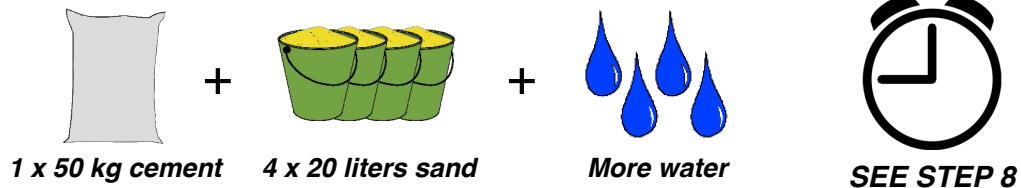
6 1st Inner Layer



Use the same concrete mixture as in step 1. Apply a 1-1.5 cm thick layer to the inside of the cistern. Make sure to fill all gaps around the pipes you fitted in step 4. This step and step 5 can be completed *simultaneously*. When you reach the base of the cistern, create a 5 cm high ramp between the wall and the base. Subsequent layers will build this ramp further. Wait at least 8 hours for the layers from steps 5 and 6 to dry.

7

2nd Inner Layer

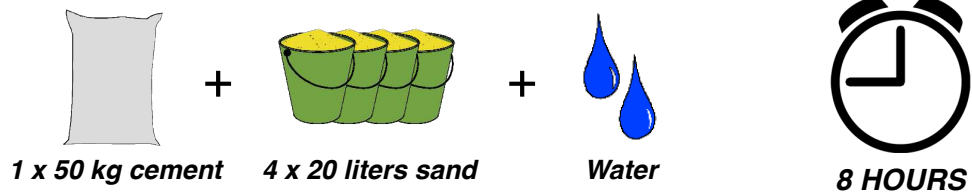


Use a concrete mixture with more water than in step 1, but with less water than step 2. Use this thin layer to coat the inside of the cistern, especially make sure to seal all cracks in the previous layers and around the pipes.

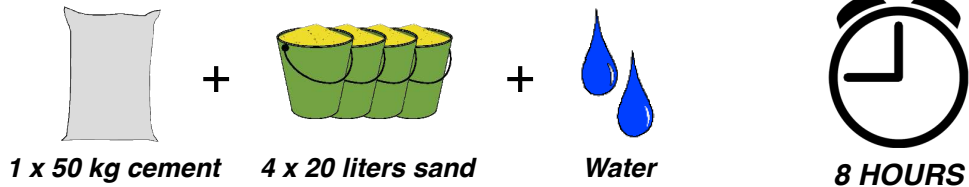
This step and step 8 can be completed *simultaneously*.

8

4th Outer Layer



Use the same mixture as step 1, but with extra fine sand for a final outer coat. Once this layer is starting to dry, trowel over it gently, applying water or dry cement as necessary to get a smooth surface with no cracks. This step and step 7 can be completed *simultaneously*.

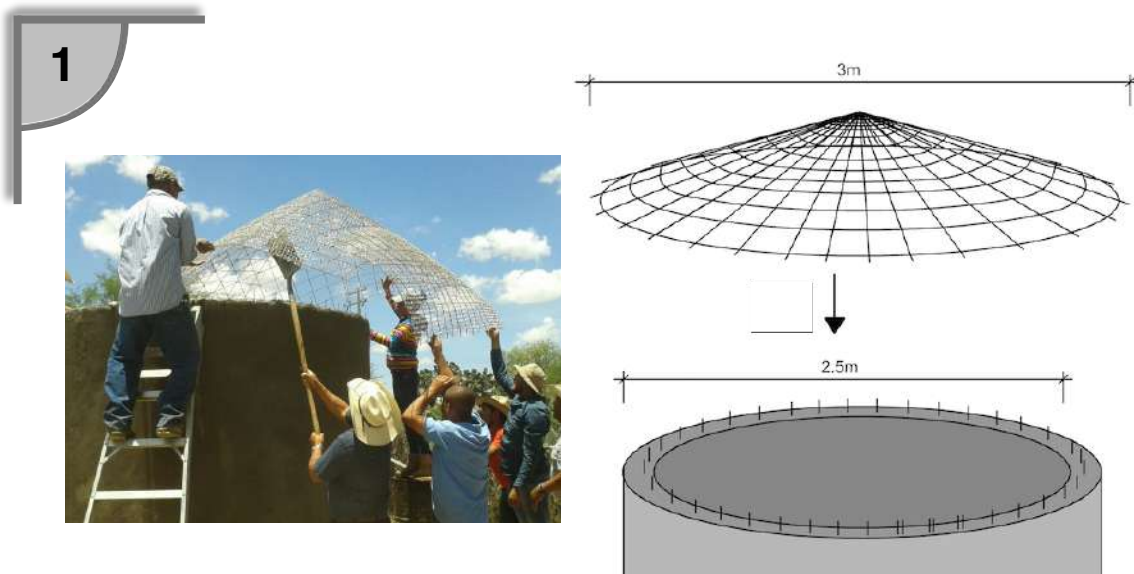
9**3rd Inner Layer**

Use the same mixture as step 1, but with extra fine sand for a final inner coat. Make sure to fill all cracks.

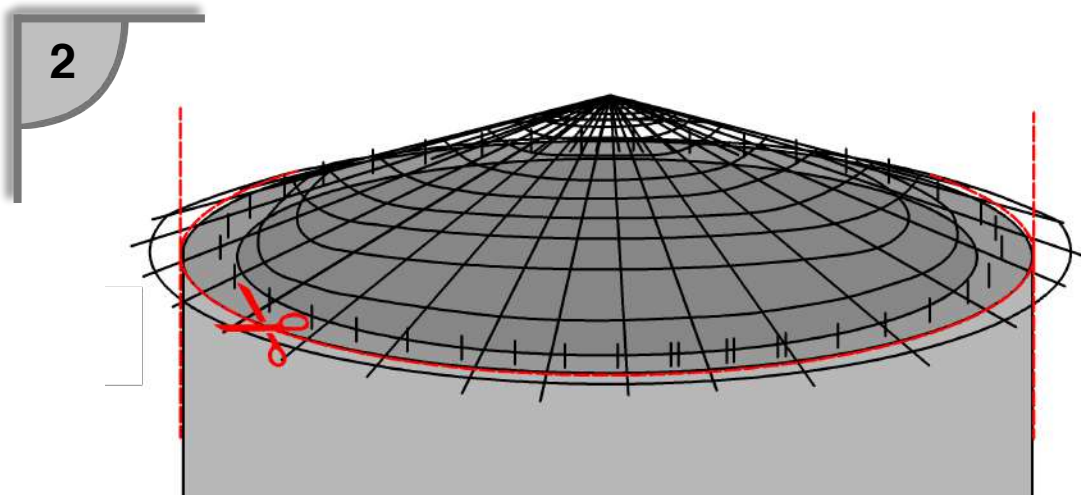
10**4th Inner Layer**

For the final inner waterproofing coat, mix cement with water and plaster it as a thin layer across the inner wall of the cistern. (If desired, you can also use a commercial cement additive sealant for waterproofing.) Make sure to seal all cracks and seal the gaps around the edges of the pipes. Put a few inches of water inside the cistern as you install the roof to keep the walls moist. Keeping the concrete humid prevents cracking and ensures a more uniform cure. When you are done with this step, the inner wall should be as smooth as the one pictured here. In step 8, notice the pipes sticking out for connections and the rebar sticking up to hold the roof. Time to put on the roof!

3.2.6 Cistern roof

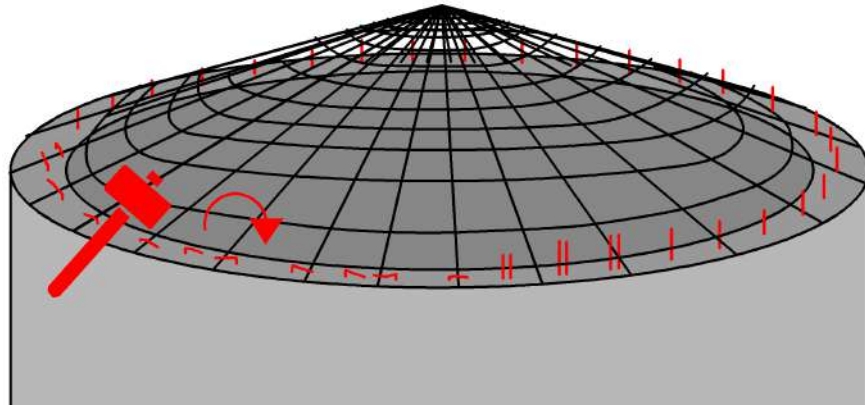


Place the roof reinforcement mesh, assembled in section 3.2.3.4, on top of the concrete cylinder.



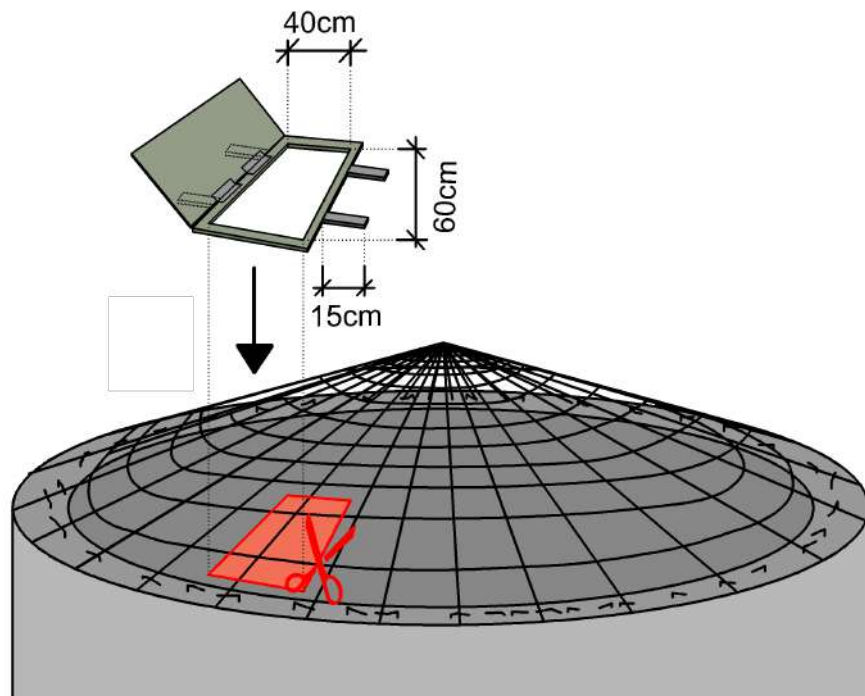
With the shears and bolt cutters, trim the edge of the roof piece so it extends only slightly, about 1 cm, past the edge of the cylinder.

3



Bend the top 5-10 cm of rebar mesh protruding from the top of the cylinder down, to fasten the roof in place. If you did not leave enough space, fasten the roof to the cylinder with twisted wire.

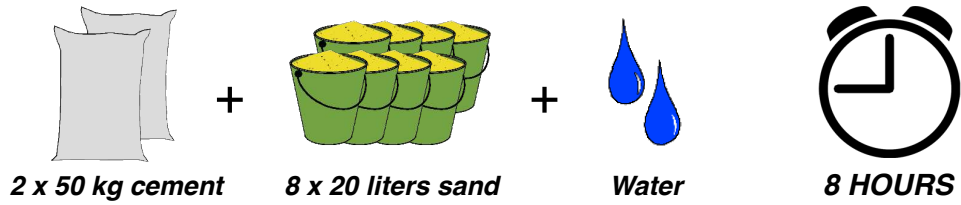
4



Using the shears and bolt cutters, cut a 40x60 cm hole in the roof, as close to the edge as possible. Fasten the door in place with twisted wire.

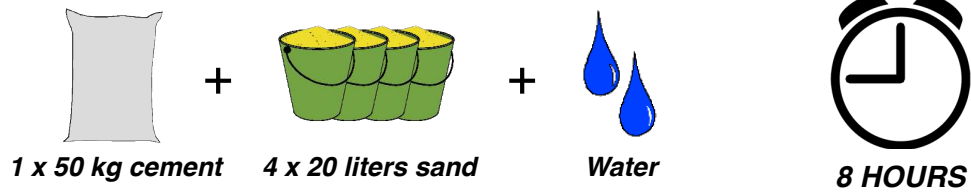
5

1st Roof Layer



Mix concrete using two 50 kg bags of cement, 8 buckets of sand, and water. The mix should be stiffer than the mixes used for the walls. Apply the mixture in layers until the roof is 1.5-2 cm thick of concrete.

6 2nd Roof Layer



Use the same mixture as step 1 of section 3.5.2, but with extra fine sand for a final smooth outer coat. Once this layer is starting to dry, trowel over it gently, applying water or dry cement as necessary to get a smooth surface with no cracks. In the photo above, notice how the *tap* is high enough to fill a water jug and the *measurement point* is positioned directly above it.

Your cistern is now structurally complete, it just needs to cure. Make sure there is water in the cistern to keep the walls moist and that the exterior is not in direct sunlight. Cover it with a tarp, plastic, or a shade structure to prevent cracking as the concrete sets over the coming days. Wait 8 hours before painting.

3.2.7 Finishing touches

1



Paint the cistern! You can paint it however you like! We make a natural white paint that helps keep the cistern cool. To make the paint, mix:

- 1 bucket of water
- 2 kg of grain salt
- 1/2 bucket of lime
- 1/2 bucket of nopal cactus juice

When these ingredients are fully mixed you should have a white paint. Test by painting a rock. If necessary, add water to thin the paint or lime / nopal to thicken it. Paint the cistern with a brush or paint roller.

2

Using remaining concrete, build a small ramp on the ground beneath the *tap*, ideally running into plants or a garden. This will carry any dripped water away from the cistern and prevent erosion near the base.

3

Attach the cistern to a roof and first flush system. See the next chapter for more instructions for how to setup your roof, piping, and first flush system to safely and effectively harvest rainwater!

Chapter 4. Roofs and gutters

The previous chapters deal with storing rainwater (chapter 3). *But how do you actually capture the rain?*

To harvest rainwater, you need a surface — like a roof — on which the rain will fall. The larger, the better (to calculate the minimum surface area a household needs, see chapter 2). The rain hits that surface and runs off, normally falling on the ground. Our goal is to collect that rainwater as it flows off the roof. Since many roofs are sloped in one direction and the water flows one way, most designs require only a single gutter. Roofs comprise the majority of rainwater harvesting systems, but rain can also be captured from a solar array, tarp, parking lot, road, field, or any other surface on which it falls. For simplicity, this chapter focuses exclusively on roofs.

The following sections explore common roof types found in central Mexico and how to attach collection pipes and gutters to each. Combinations can also be made: you can collect water off a cement roof on your house and a corrugated sheet barn structure, directing the rain into the same first flush system and cistern.

This section covers the following roofs:

- 4.1 Concrete gable roof
- 4.2 Concrete flat roof
- 4.3 Corrugated or tile roof (gabled or flat)

The techniques described can be easily adapted for other building materials including adobe, compressed earth block, mud, and straw, tiles, and shingles.

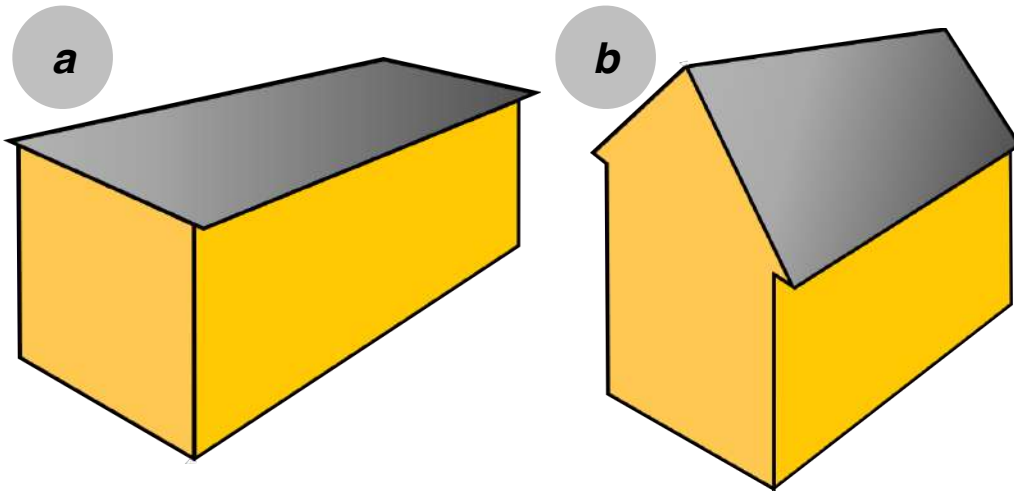


Figure 4.1 — Roofs come in many different shapes. For this chapter, we simplify them into (a) flat roofs and (b) gable roofs.

The same principles apply when capturing rainwater over a much larger surface like a hillside or a parking lot. The surface must be designed so the majority of the water runs in a single direction to be captured and held in a large storage area like a reservoir. We do not cover large-scale rainwater harvesting, whether passive or active, in this manual. See the resources section for information about larger-scale rainwater harvesting.

4.1 Concrete gable roof

A concrete gable roof is made of cement and in the shape of an upside down “V”, shown in figure 4.1b. The techniques outlined in this section also apply to a gable roof made from other materials including adobe, mud, and plaster.

When rain hits the roof, it will run down towards the bottom edge. You can collect that water with the gutter systems described in section 4.4, or use a special row of bricks that run to a single gutter. This section describes the brick-single gutter method as shown in figure 4.2.

The following sections lay out the materials and tools required to build the setup shown in figure 4.2, and walks through the steps and details.

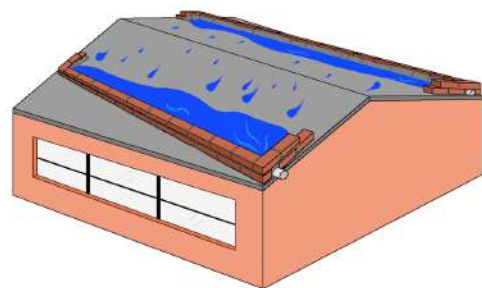


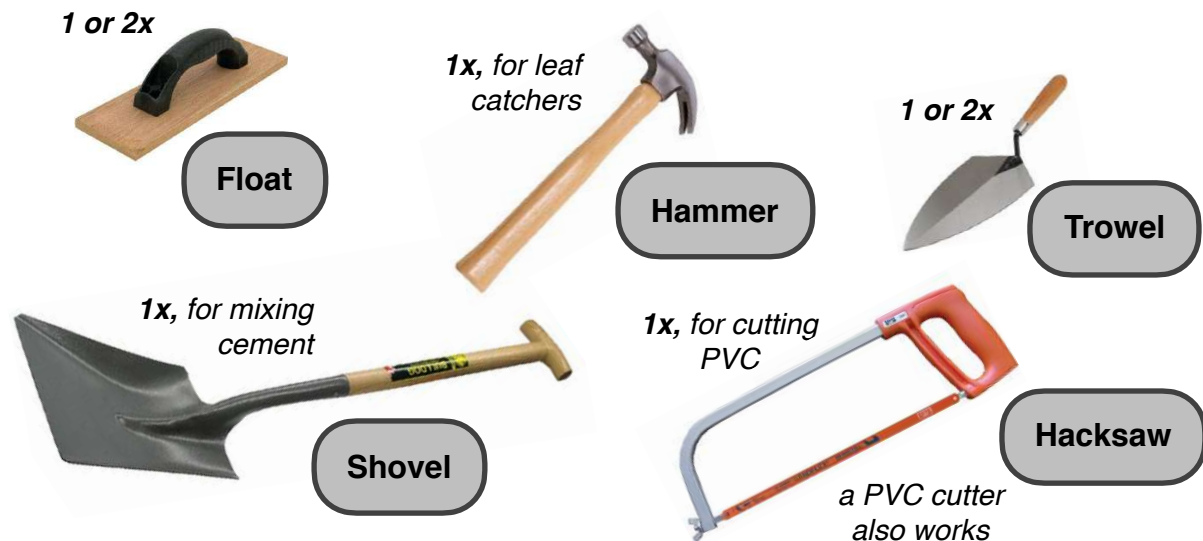
Figure 4.2 — Bird’s-eye (top) view of a concrete gable roof with brick rain catchment. Notice how the bricks slope up the roof to one side, causing the water to run to the pipe in the corner. You can catch rain off one side of a gable, or both.

4.1.1 Materials

Image	Material	Unit	Quantity
Q1	Cement	50 kg bag(s)	1/2
Q2	Sand	20L bucket(s)	2
Q3	Water	20L bucket(s)	a few
Q4	Bricks	piece(s)	sufficient to make a double row across your roof, then 10 more
Q5	2" sanitary PVC, 1 meter long	piece(s)	1
Q6	Plastic mosquito mesh	5" x 5" piece(s)	1
Q7	Cement nails	piece(s)	4

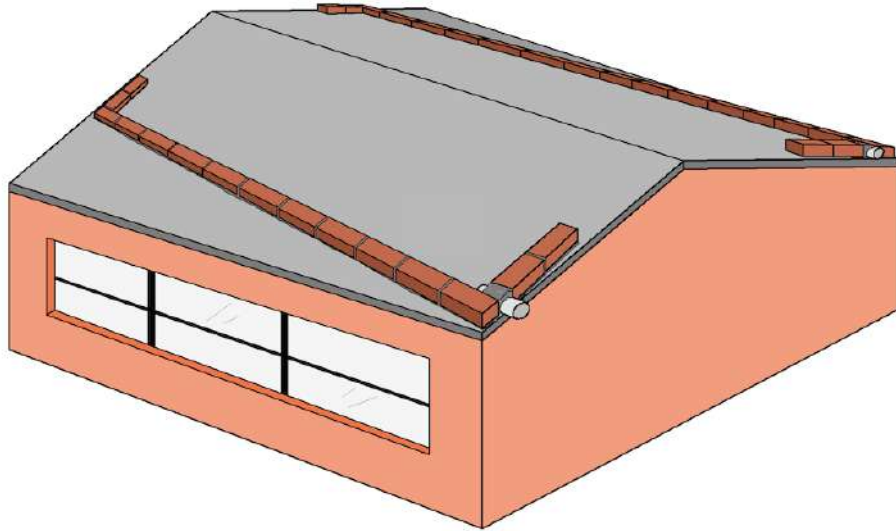


4.1.2 Tools



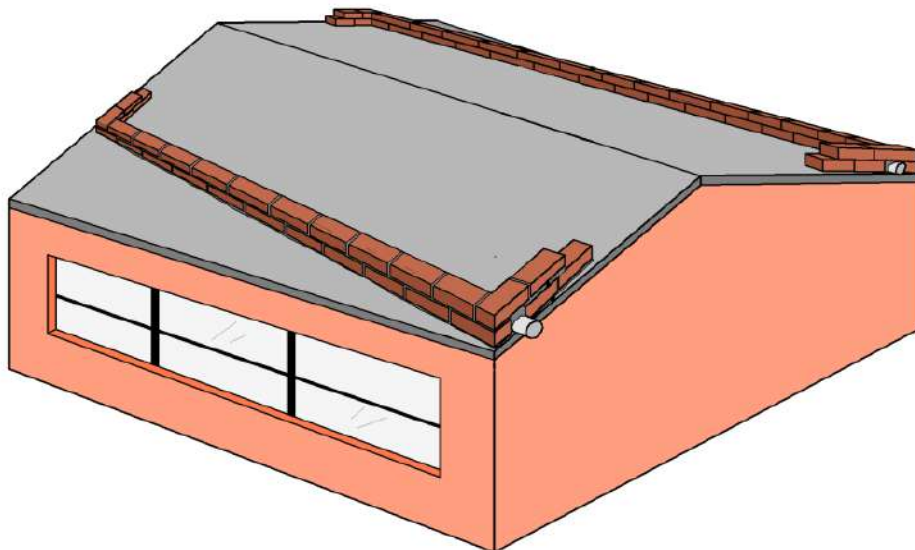
4.1.3 How to build the brick wall for a concrete gable roof

1



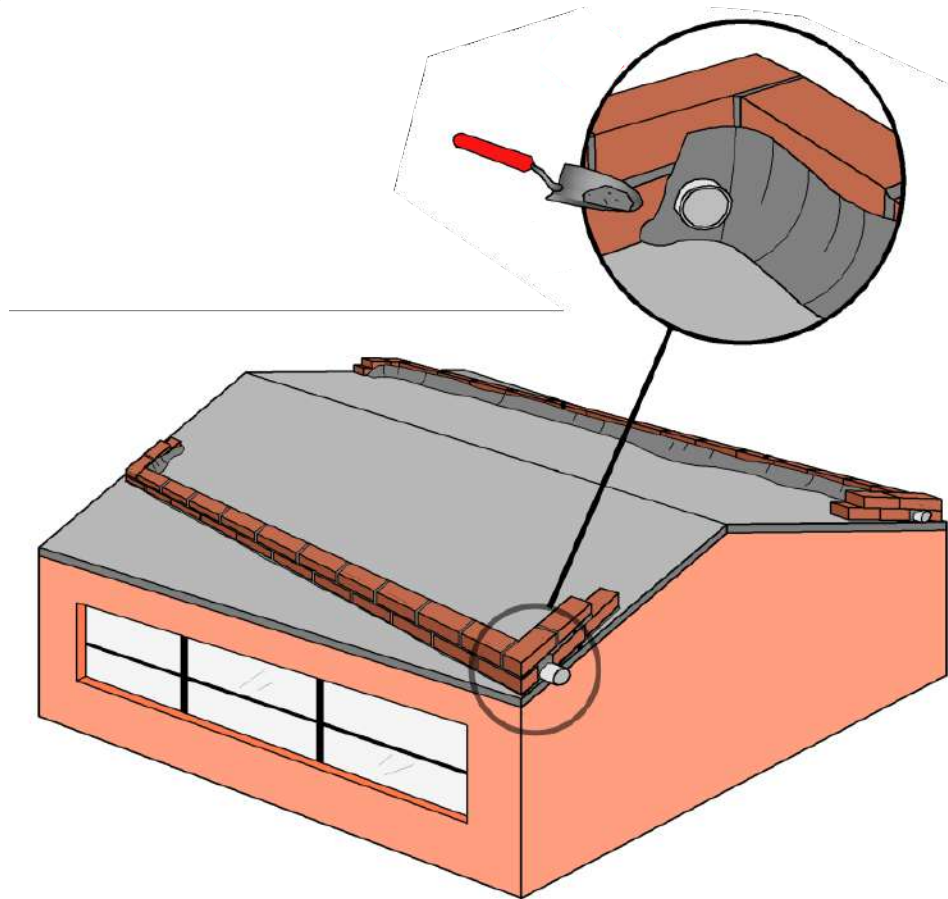
Build a single-layer brick wall going diagonally up and away from the corner where you will place the tube. Position the tube in its niche. The wall should turn at the corner and go up the roof for two to three brick-lengths on either side as shown.

2



Add a second layer of bricks above the first, making sure to cement the tube well.

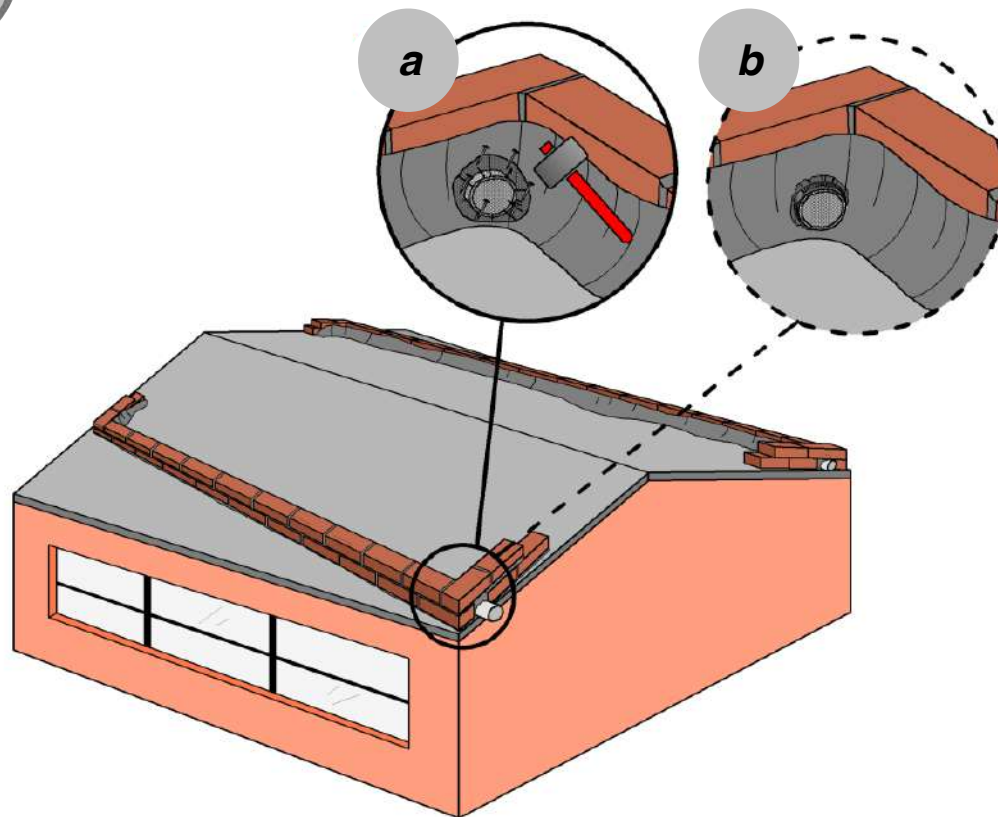
3



Seal the brick wall by making a concrete ramp as shown in the drawing.

Use either a mixture of fine sand, water and cement (no gravel) or plain cement and water to make sure that the ramp is water-tight.

4



Add the leaf-catcher mesh on the concrete side of the wall by either (a) hammering nails through the mesh and into the concrete ramp, over the mouth of the tube or (b) using a hose-clamp. The hose-clamp method (b) must be fastened before imbedding the tube in concrete in step 1.

4.2 Concrete flat roof

A brick wall can be built to collect water from a concrete flat roof in a similar manner as shown with a concrete gable roof. "Flat" is a misnomer as no roof is ever completely flat. Most roofs are designed to drain — often very slightly — to one corner or edge. If your concrete "flat" roof drains to a single corner, you can use the method described in the previous section. If it drains to an edge, however, we recommend a slightly different approach.

This method, shown in figure 4.3, uses regularly-spaced 2" PVC pipes embedded in a brick wall to collect the water. The rest of this section gives step-by-step instructions for installing this system.



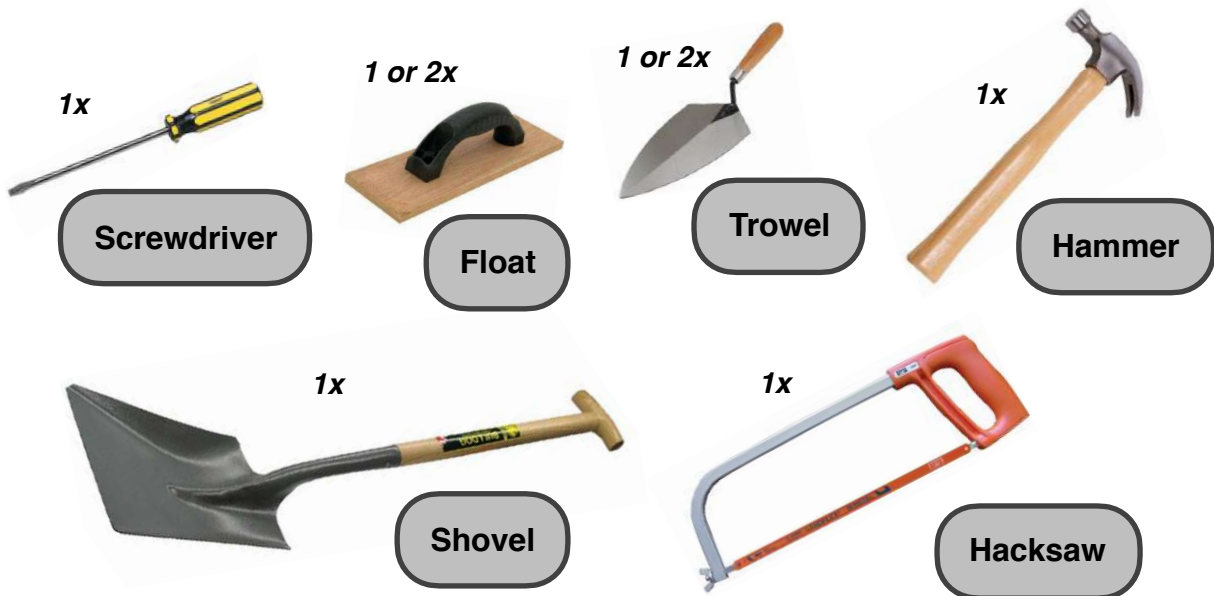
Figure 4.3 — (a) The piping system is connected to four pieces of 2" PVC that carry the water off the roof. The piping is held in place by a double layer of cemented brick. In (b), one concrete flat roof is connected to two cisterns.

4.1.1 Materials

Image	Material	Unit	Quantity
R1	Cement	50 kg bag(s)	1/2
R2	Sand	20L bucket(s)	2
R3	Water	20L bucket(s)	a few
R4	Bricks	piece(s)	enough to make a double row across your roof, then 10 more
R5	2" sanitary PVC, 1 meter long	piece(s)	As many as you need (at least 4)
R6	Plastic mosquito mesh	5" x 5" piece(s)	Same as R5
R7	Cement nails	piece(s)	4 x R5



4.3.2 Tools

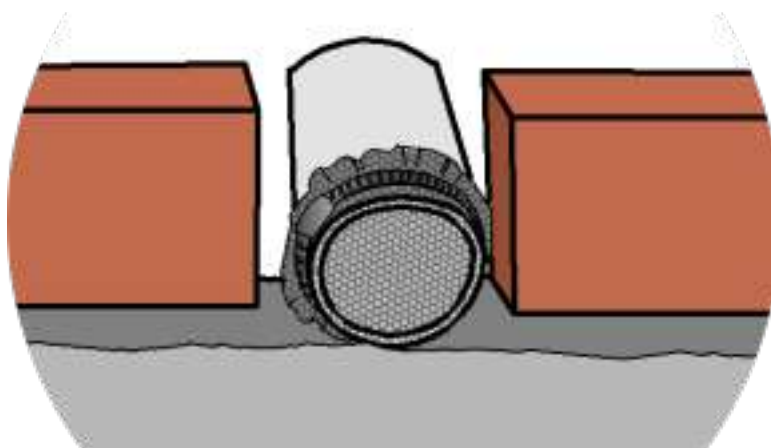


4.3.3 How to build the brick wall for a concrete flat roof



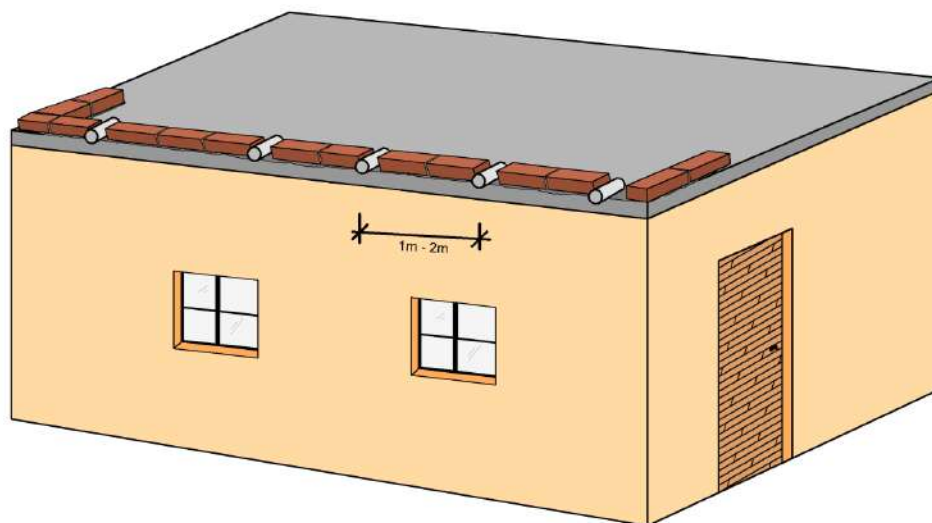
Cut your tubes to the appropriate size, about 30 - 50 cm in length. The tubes should be long enough to protrude 10 cm beyond the edge of the roof when flush with the uphill side of the bricks.

2



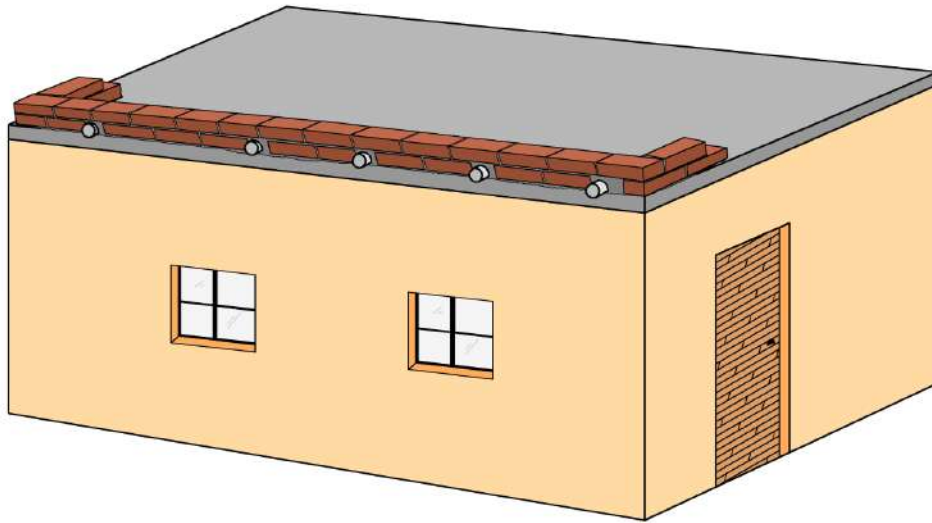
As in section 4.1, you can use hose clamps or nails to secure your leaf-catcher screens to the tube openings. If you choose to use hose clamps, clamp the mesh to the tubes now, as shown in the figure above. Make sure the mesh is on the roof-side of the tubes! If you are using nails, you will secure the leaf catchers in step 6.

3



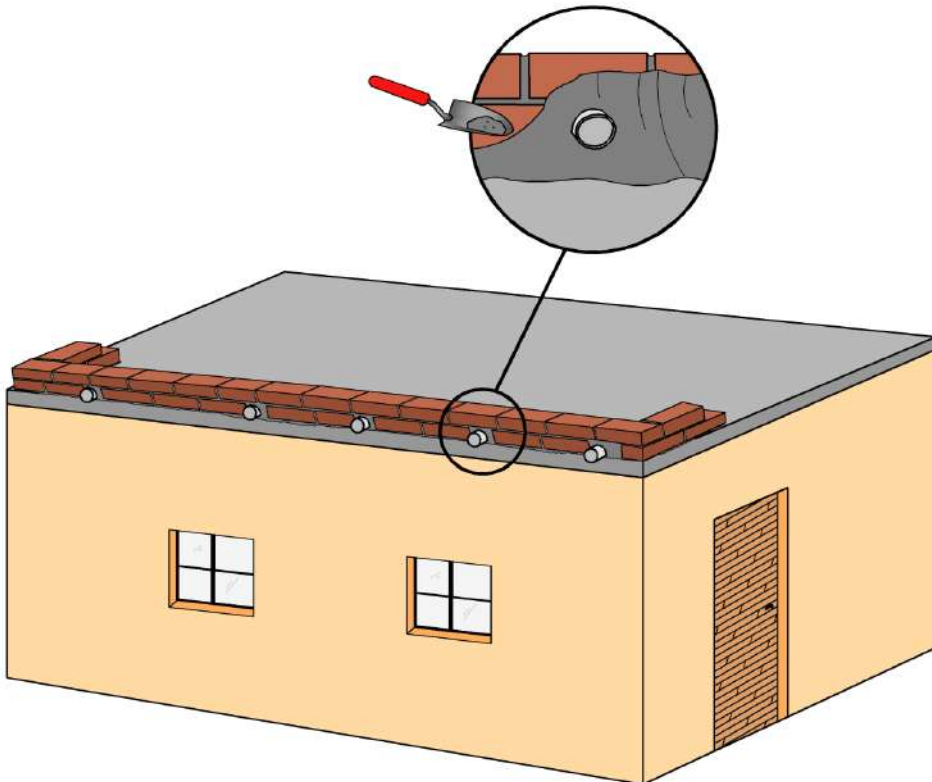
Using cement, build a one-brick-tall wall along the low edge of the roof, inserting a piece of tube every 1 to 2 meters as shown. At the roof's corners, add two brick-lengths running up the sides. Make sure to cement the tubes tightly to the brick.

4



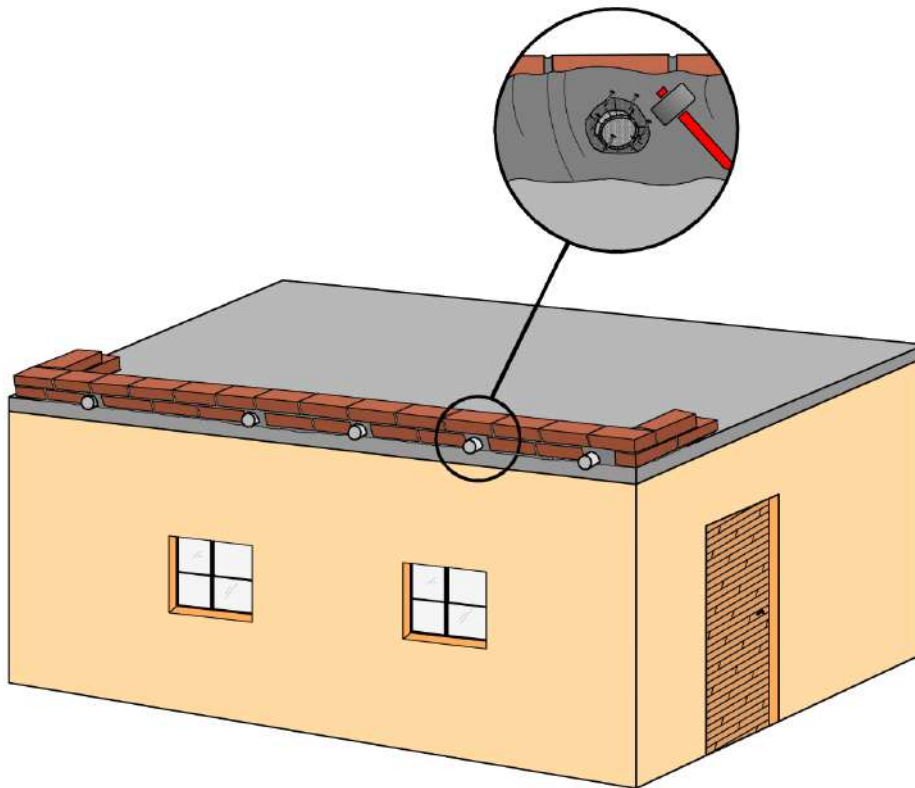
Using cement as mortar, add a second layer of bricks above the first.

5



Similar to step 3 in section 4.1.3, use a fine cement (only cement and water) to build a ramp on the uphill side of the brick wall. This prevents the water from leaking through the brick or mortar.

6



After the concrete has dried, if you did not add leaf-catcher meshes in step 2, add them now: Cut the mesh to fit over the tubes' mouths. Fix them in place by hammering concrete nails into the cement ramp.

7



Finish the roof by attaching the appropriate PVC parts (elbows, tees, and tubes, most likely) to bring the water to your first flush system. All tubing must slope down, so water doesn't get stuck.

4.4 Corrugated sheet, tile, and shingled roofs

This section covers two simple, low-cost ways to collect water off of a non-cement roof. The first method, a **tube** that curls around the edge of the roof, can only be used on particularly rigid roofs, like a corrugated polycarbonate roof on a metal frame, for example. A **gutter**, however, can be used on any roof. The rainwater rolls off the roof and drops into the gutter, where it is carried through a tube system to the first flush. Gutters can be made from pretty much any material and range from fancy (commercial aluminum and PVC gutters) to hacked together (a bent piece of corrugated aluminum or a sawed up piece of PVC pipe, for example). Since you can make a gutter out of practically any material, this manual does not cover gutters in great detail. The following section details the construction of a **tube** harvester system, a very common local setup. If you choose to build a **gutter**, check out your local hardware store, see what materials you have lying around, and good luck!

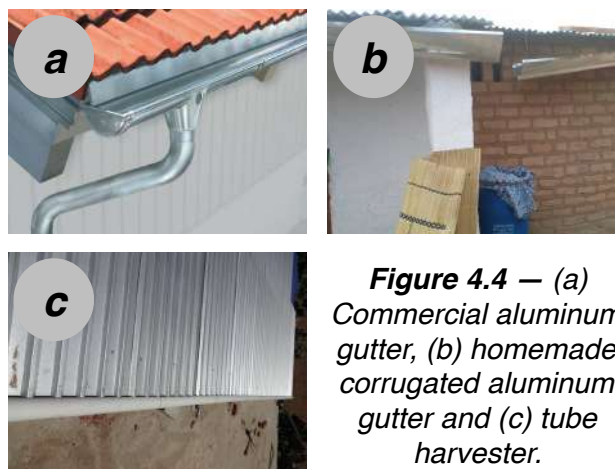


Figure 4.4 — (a) Commercial aluminum gutter, (b) homemade corrugated aluminum gutter and (c) tube harvester.

4.4.1 Tube harvester materials

Since tube harvesters are prone to getting clogged with leaves, you need a rigid roof that overhangs and has no leafy trees above it. To build the tube harvester, you need the following materials:

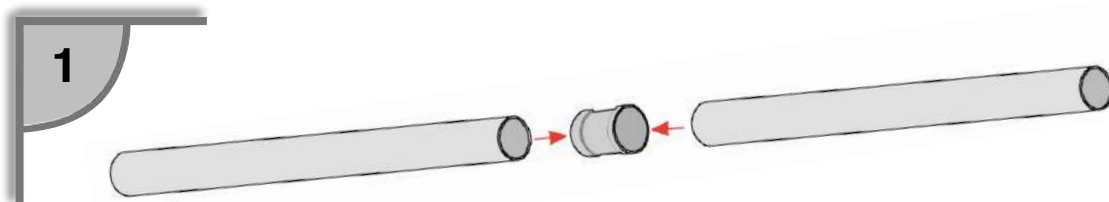
Image	Material	Unit	Quantity
T1	4" PVC tube	meter(s)	the length of your roof
T2	Wood, plastic, or rubber shims, 10cm x 2cm x 0.5cm	piece(s)	1 per meter of roof length
T3	Nails	piece(s)	20 or more
T4	Iron wire	meter(s)	10 or more
T5	PVC Glue	can(s)	1
T6	4" linear PVC connectors	piece(s)	1 per 3 meters of roof length



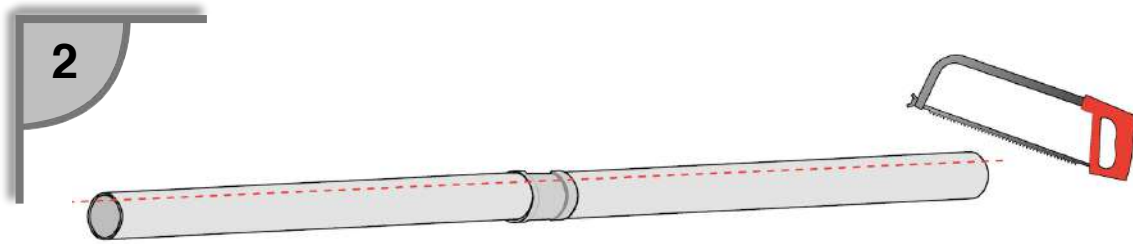
4.4.2 Tube harvester tools



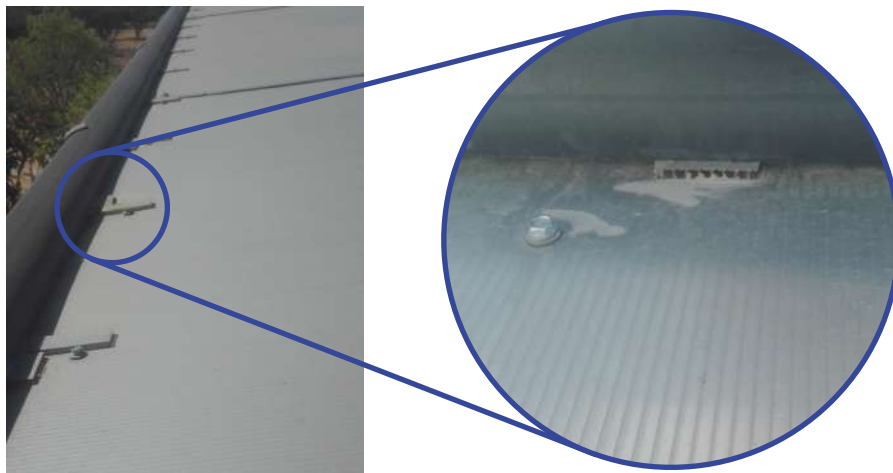
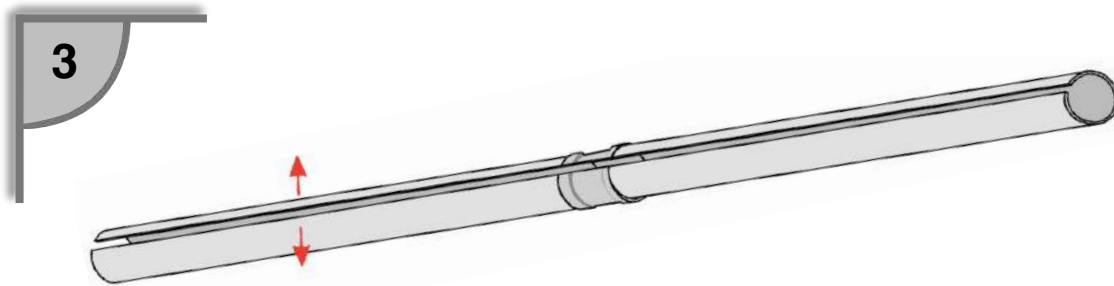
4.4.3 How to build and install a tube harvester



Create a tube harvester the length of your roof's edge by connecting tubes with linear adaptors and PVC glue. If you are connecting multiple roofs or surfaces, make a tube harvester for each edge.

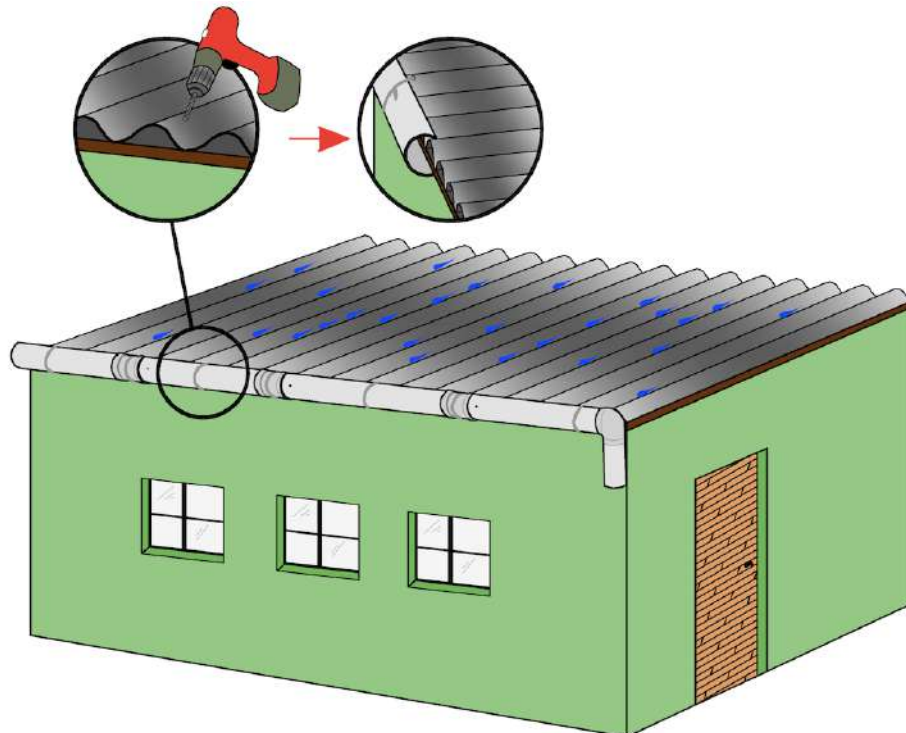


Using a handsaw (pictured), jigsaw, or table saw, make a cut lengthwise down the entire pipe. Do not cut all the way through the pipe! If using a flat roof like corrugated polycarbonate, this should be sufficient. If using an uneven roofing surface like Spanish tile or corrugated aluminum, cut another slit about a centimeter away from the first one, leaving a 1cm wide gap to better fit snugly over the roof's edge.



Once the appropriately-sized slit has been cut, pry the tube open and snap it around the edge of your roof. It should fit tightly. If your roof is flat, you will notice that there is no easy way for the water to enter the gutter. To fix this, place shims every meter between the upper edge of the roof and the edge of the gutter. The shims should be made from plastic or rubber and be about 0.5 - 1 cm high to allow the water to enter freely.

4



The gutter needs to be fixed securely to the house to hold the weight of the rainwater. Drill holes into the strongest material fixed to the roof. A metal or wooden reinforcement beam is ideal. If this is impossible (your roof has a long overhang, for example) drill holes directly into the roofing surface. Fasten the gutter to the roof by feeding 40 centimeter pieces of wire through each hole and twisting them tightly around the gutter.

Chapter 5. First flush systems

Once the roof has been prepared with a system to collect the rain — as described in chapter 4 — the water needs to be stored. However, when falling on a roof, rain picks up dirt, dust, leaves, bird excrement, dead flies, bacteria, the list goes on. It is much easier to treat this water before it enters the cistern than trying to treat the accumulated contaminants in the cistern itself. This is where a first flush system comes in. This chapter covers some practical design considerations for the first flush system including sizing the first flush, choosing a material, and adding leaf filters. The second half of the chapter outlines the step-by-step processes of building the barrel and PVC first flush systems the we use.

5.1 First flush practical considerations

The first flush system is an important safeguard against biological contaminants and assuring your stored rainwater is as clear as possible. A first flush system separates the first water of every rain event. This first water carries the majority of the physical contaminants off the roof. These contaminants get separated in the first flush — effectively washing your roof — and the rest of the clean rainwater is free to enter the cistern. The amount of water you need to separate depends on your roof area and other environmental factors. The water that fills the first flush system is not for drinking, but is perfect for other uses, like watering a garden.

If sized correctly, a first flush system should be emptied after every rain event; if your first flush is larger than it needs to be, you may not need to empty it completely. The next section guides you through the process of determining an appropriate volume for your first flush system.

Note: First flush systems guard against *some* biological contaminants, but the water in your cistern will still be biologically active! Having a first flush is *not* sufficient treatment to make the water potable. For biological treatment steps, see chapter 7.

5.1.1 Sizing your first flush

The area of your roof determines the number of liters you need to collect in the first flush system. Make sure you separate enough water by using the following equation:

$$\begin{array}{c} \text{Roof area} \\ \text{m}^2 \end{array} \times \begin{array}{c} \text{Cleanliness} \\ \text{factor} \end{array} = \begin{array}{c} \text{Amount of} \\ \text{liters to} \\ \text{separate} \end{array}$$

Cleanliness factors:

- A cleanliness factor 0.5 is an established factor which approximates the average roof's cleanness. Use 0.5 when you clean your roof regularly.
- Use a higher cleanliness factor (we recommend 2.0) if you live in a dusty area, have overhanging trees or do not regularly clean your roof.
- Generally, we recommend using a cleanliness factor of at least 0.5 to safeguard against biological contaminants.

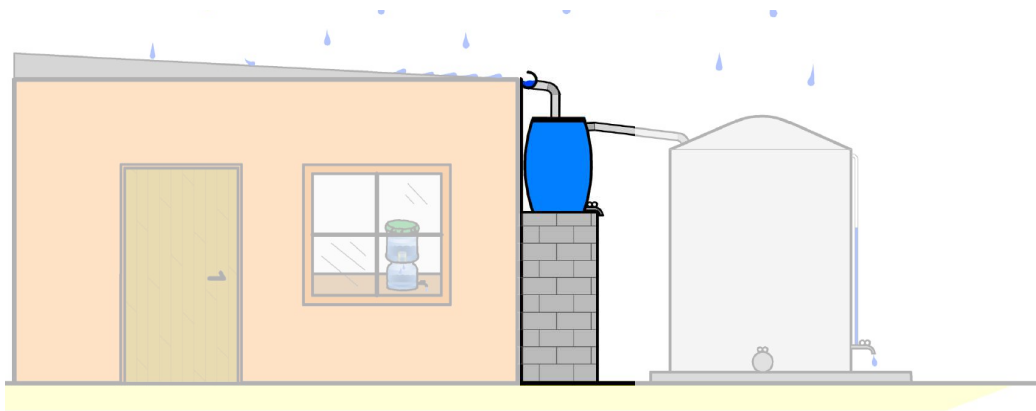


Figure 5.1 — A schematic of a barrel first flush system connecting a roof to a cistern.

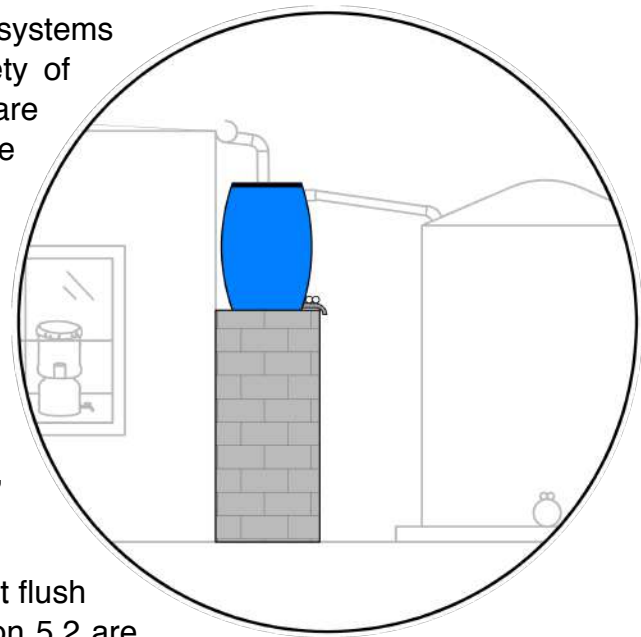
5.1.2 Different types of first flushes

Although there are many common first flush systems, ranging from expensive commercial versions to cheap homemade ones, we most commonly use two types: **PVC and Barrel**. In general, we recommend a PVC design when you need to separate **less than 50 liters**. When you need to separate **more than 50 liters**, consider using a **barrel** for your first flush system.

To make a final decision about your system, also consider costs, space, and materials. This section describes some of the differences between a barrel and PVC first flush system. The rest of the chapter is dedicated to step-by-step instructions to building each type of system.

Barrel

Barrels are great options for first flush systems because they are easy to find in a variety of sizes (between 50 and 200 liters) and are inexpensive. If your barrel is larger than the volume you calculated in the previous section, you only need to remove that much water from your barrel after each rain event. For example, if you use a 200 liter drum for a first flush system but calculated that you need to separate 80 liters: after each rain event, make sure to drain at least 80 liters from your drum, leaving the remainder.



While there are many ways to design a first flush with a barrel, the steps described in section 5.2 are some of the best practices we have designed at Caminos de Agua.

PVC

A PVC or pipe first flush system is more flexible than the barrel since it can be sized to any volume. A single meter of pipe has a set volume (see Table 5.1), depending on the pipe's diameter. To calculate which diameter and length of pipe to use, plug the amount of liters to separate from section 5.1.1 into the equation:

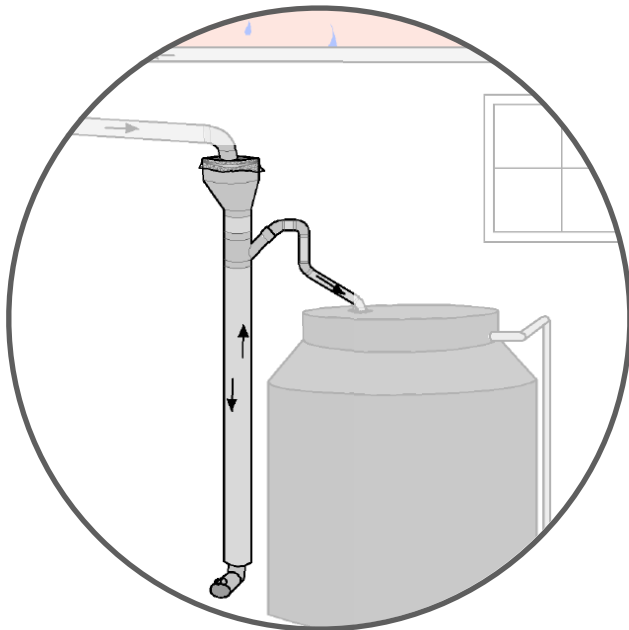
$$\frac{\text{Quantity of liters to separate}}{\text{Capacity of PVC}} = \text{Minimum length of PVC for first flush}$$

Example: Find the capacity of PVC from *table 5.1*. Use any PVC diameter from *table 5.1* to calculate a reasonable length, typically we recommend between one and three meters. Once your result falls into that range, use that diameter and length of PVC. For example, if we wanted to separate 20 liters using 4" PVC, we find that:

$$\frac{20}{8.9} = 2.25$$

Quantity of liters to separate Capacity of PVC Minimum length of PVC for first flush

The calculated answer of 2.25 meters falls between our recommendation of one to three meters, confirming that 4" PVC pipe is a good design choice. (Remember to consider where the first flush will be installed to make sure that your design will fit in the available area.) See section 5.3 for more details on how to build your own PVC first flush system.



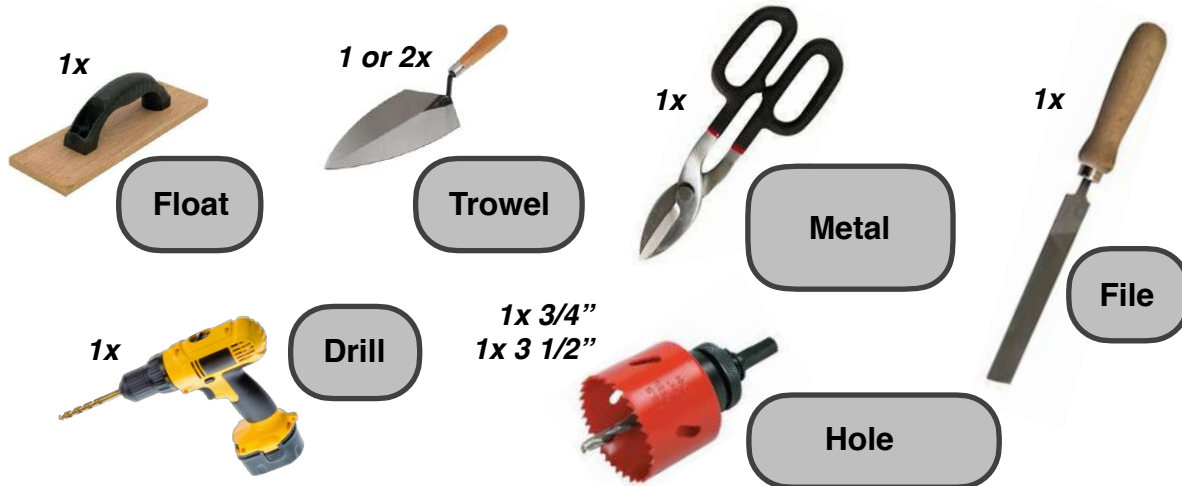
PVC Diameter	Capacity of 1m of pipe
2"	2.4 L
3"	5.4 L
4"	8.9 L
6"	18.2 L

Table 5.1 – Capacity of a single meter of PVC for various pipe diameters

5.2 Building a barrel first flush system

We recommend barrel first flush systems when you need to separate at least 50 liters of first flush (see equation in section 5.1.1). Otherwise, you are wasting drinking water that could otherwise be used in your cistern.

5.2.1 Tools



5.2.2 Materials

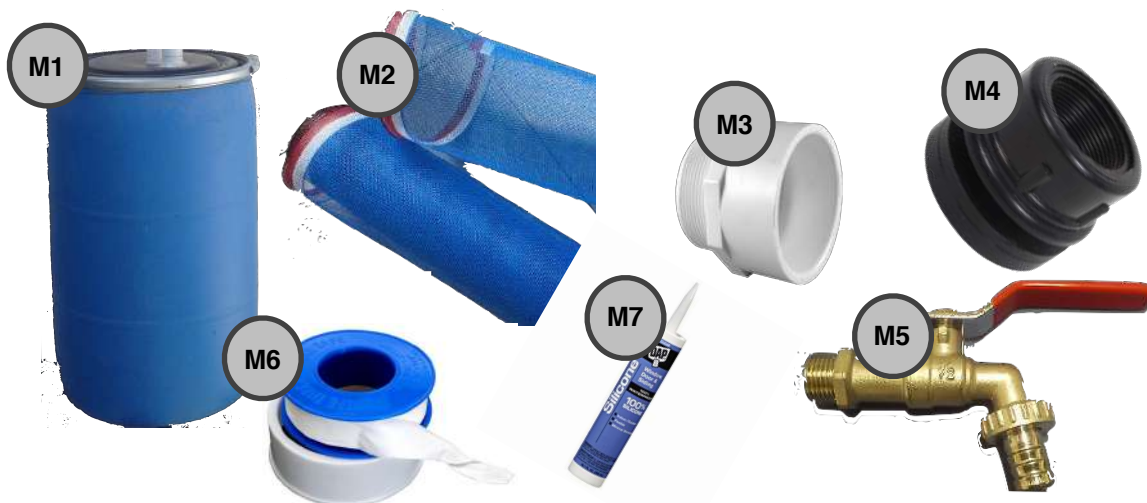
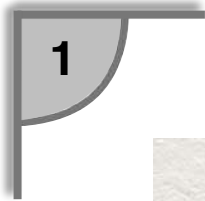


Image	Material	Unit	Quantity
M1	50 - 200 liter barrel	unit(s)	1
M2	Plastic mosquito netting	square meter(s)	1
M3	3" hydraulic male PVC adaptor	units)	1
M4	1/2" bulkead fitting	unit(s)	1
M5	1/2" tap	unit(s)	1
M6	Teflon tape	roll(s)	1
M7	Drinking-water safe silicone sealant	tube(s)	1

5.2.3 Steps to build a barrel first flush system



Cut a hole in the lid of the barrel. It should be big enough for the piping from the gutter system to enter easily.

2



Use a 3/4" hole saw to drill a hole near the bottom of the barrel.

3



Assemble the bulkhead fitting (M4) and attach the 1/2" tap (M5) with teflon tape.

4



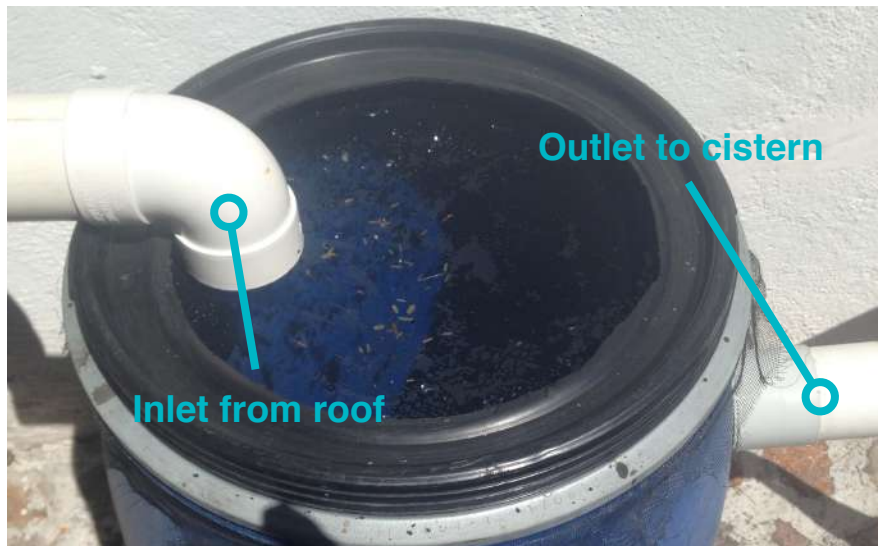
Cut a 3.5" hole in the side of the barrel, near the top, for the hydraulic PVC adapter (M3). File the hole until the adaptor screws in tightly to the plastic barrel. Cut the hole slightly bigger than the adapter piece's threading. If you do not have a hole saw and/or drill, use a knife and slowly cut out the hole.

5

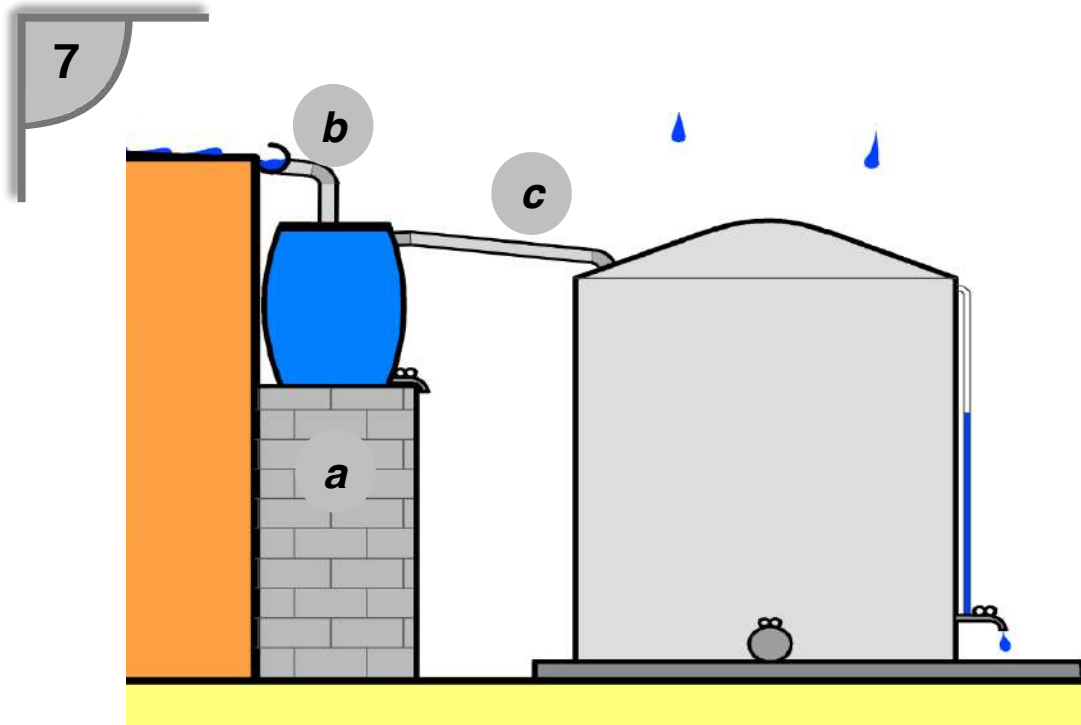


Screw the 3" hydraulic male PVC adapter (*M3*) into the hole. This outlet will connect to the cistern or screw a 3" hydraulic female PVC adapter into the inside (optional and not pictured). Tip: If hole is too large, install a male and female adapter and fill the space between with silicone.

6



Remove the barrel lid and stretch the mosquito screen over the opening. Replace the lid over the mosquito screen. The connection from the gutter system on the roof will direct the rainwater into the barrel. The mosquito screen acts as a leaf filter (section 6.1.5) for the first flush system.

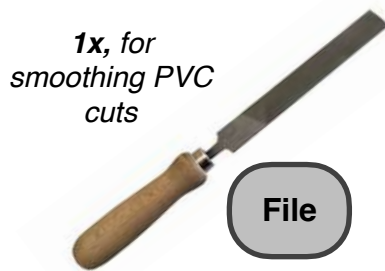


Build a (a) column or base so that the first flush barrel is elevated high enough so that the outlet from the first flush to the inlet of the cistern has at least a 1° slope (c). Place the barrel on the column and run the gutter system into the inlet of the first flush using a PVC elbow (b). Connect the first flush to the cistern with 3" hydraulic PVC (c).

5.3 Building a PVC first flush system

To build a PVC first flush system, make sure you need less than 50 liters of first flush volume from the equation in section 5.1.1. Otherwise, PVC will not have enough capacity without being impractically long. Make sure you have done the calculations in section 5.1.2 and know how long and what diameter your pipe needs to be.

5.3.1 Tools

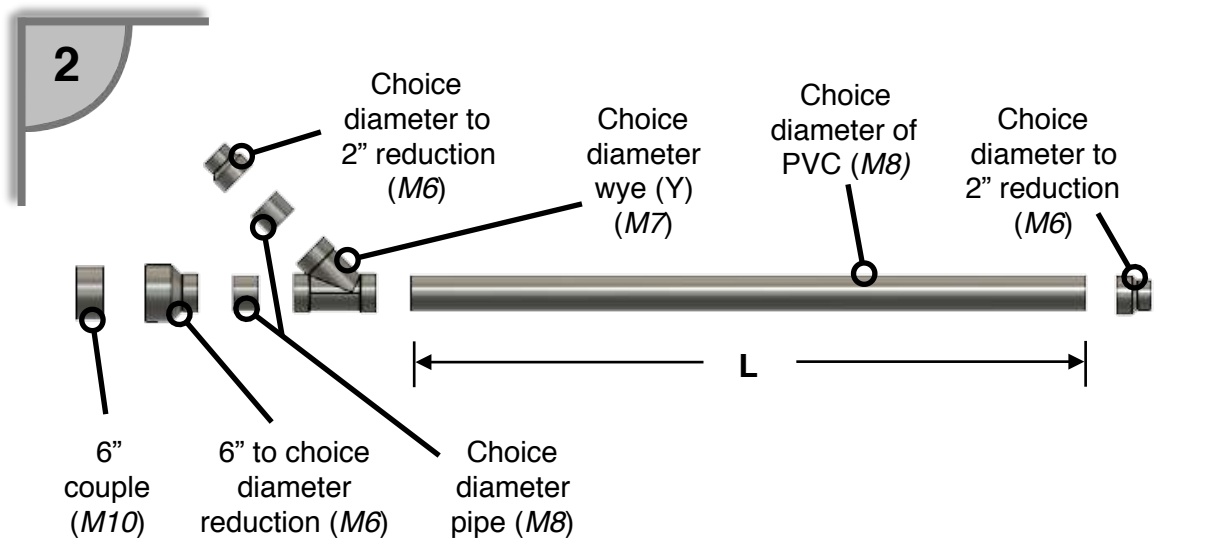
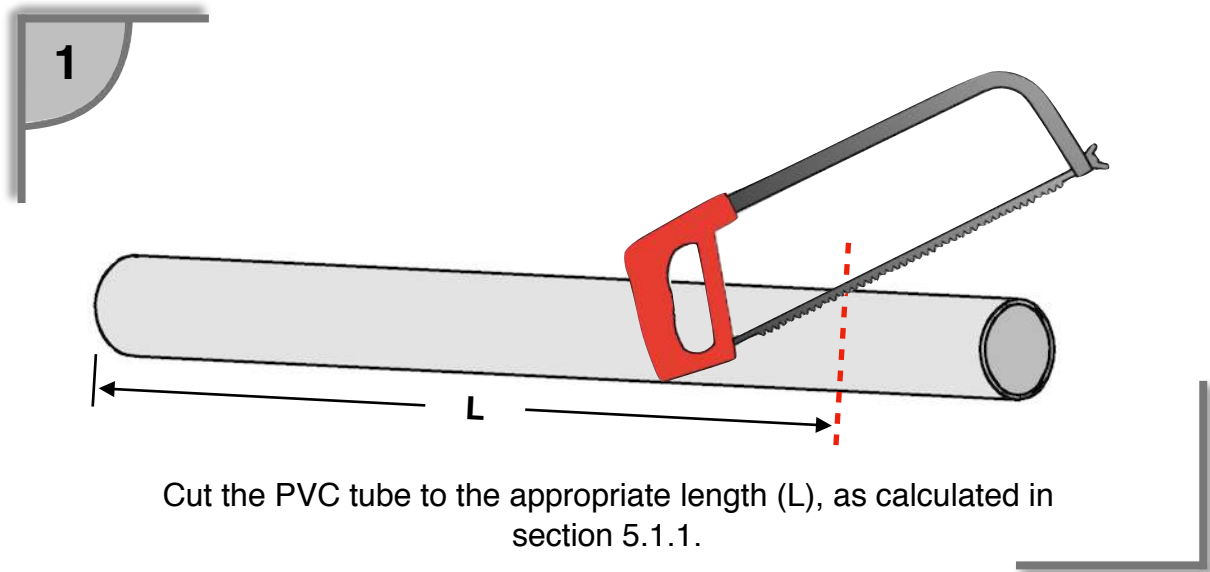


5.3.2 Materials

Image	Material	Unit	Quantity
M1	Steel wire	meter(s)	3
M2	Plastic mosquito netting	square meter(s)	1
M3	PVC cement	can(s)	1
M4	Teflon tape	roll(s)	2
M5	Nails	unit(s)	10
M6	6" to your PVC diameter of choice reduction, sanitary PVC	unit(s)	1
M6	PVC diameter of choice to 2", sanitary PVC	unit(s)	2
M7	Wye (Y) of your PVC diameter of choice, sanitary PVC	unit(s)	1
M8	Pipe of your PVC diameter of choice, sanitary PVC	meter(s)	1-4
M8	2" PVC pipe, sanitary	meter(s)	1-4
M9	8" hose clamps	units(s)	1
M10	6" PVC couple, sanitary	unit(s)	1
NA	Assorted 2" sanitary and hydraulic PVC parts, dependent on local availability	piece(s)	4-10



5.3.3 Steps to build a PVC first flush system



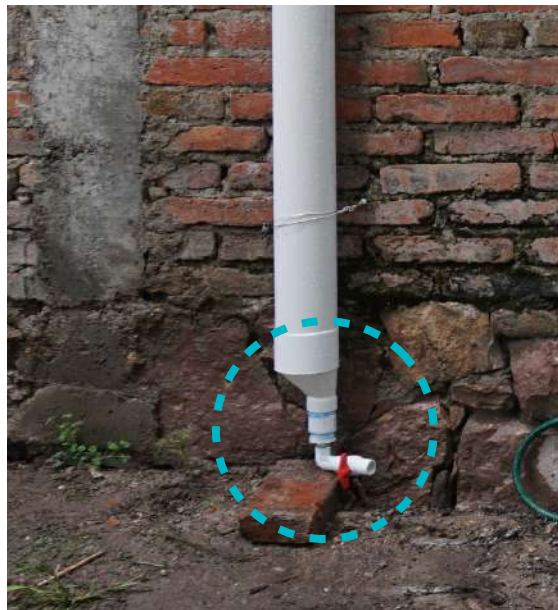
Lay out the pieces in the order shown. Fit them all together *without* glue. Make sure all the connections are snug without any space for wiggling. The long segment with length L is the piece that you cut in step 1.

3



Glue the connections one by one: Clean both surfaces. Rough them up with a piece of sandpaper or file. Apply a quick, smooth coat of cement to both surfaces. Insert the inner tube into the fitting, turning slightly. Once you reach the stopping point, make sure the piece is oriented correctly then stop turning. Wipe off excess PVC cement to make the bond dry more rapidly. See section 6.2.4 for more details on strong PVC joints

4



Attach a ball valve to the bottom of the system. To do so, you often need to transition from sanitary to hydraulic PVC. Locally available parts will vary greatly. Options may include a special sanitary to hydraulic connection or a hydraulic fitting to a 2" sanitary adaptor or pipe and reducing down to 1/2" hydraulic pipe. The bottom of the system should have an open/shut valve that allows you to store and release the water.

5



Add mesh netting (M2) to the top of the 6" PVC couple with hose clamp (M10). The elbow should rest on top of the mesh as shown. The elbow joins the gutter to the first flush system.

6



Fix the system to the wall with wire and nails. The system can rest on the ground, be supported by a structure or be suspended. Modify these instructions as you see fit depending on your wall type (i.e. if it is a wooden wall, use wood screws). Be creative. Check out the use of a tree in the photo above!

7



Add the remaining gutters and tubing to connect water from the roof to the first flush system and from the first flush system to the cistern. Each system will be unique in its installation.

8



Direct the water drained from the first flush for other uses like a tree or garden!

Chapter 6. Connecting it all: Gutter and pipes

After choosing and preparing a site, building a cistern, installing a first flush system, and setting up your roof to collect rainwater, the components need to be connected as a single system. This chapter first walks through various design considerations then lays out some specific best practices. To inspire your creative process, the chapter ends with photos of innovative rainwater harvesting systems.

6.1 Design considerations

When figuring out how your roof will empty into a first flush container and how that first flush will overflow into your cistern, there are a number of design considerations to take into account. This section goes through choosing the right pipe, securing that pipe to the wall, and keeping small animals out of the system.

6.1.1 *Choosing a type of pipe*

Although the simplest rainwater capture systems do not involve plumbing — a bucket placed outside in the rain does the trick — we recommend some sort of gutter — first flush — cistern combination to maximize the amount and quality of clean water you can collect. Regardless of where in the world you are working, you'll need something to capture the water off of your surface. It could be a proper gutter, a bit of bent aluminum roofing, a concrete spout, or, as we recommend, a piece of PVC pipe. Be aware that each material has its cost, lifetime, flexibility, thermal, and ease-of-use limitations, among other advantages and disadvantages.

If you use PVC, there will be different varieties available. In central Mexico, the most common affordable options are hydraulic and sanitary PVC. We usually work with the thinnest and most economical option available (sanitary) that also has a large enough diameter to carry the water we need (see the next section).

6.1.2 *Choosing a pipe diameter*

While we have discussed piping in previous chapters, we did not illustrate how to determine the diameter of the pipe to use to connect the parts of your system. Your roof area dictates the appropriate pipe diameter. The following table shows the correct diameters based on roof area.

Roof area (m ² or square meters)	Pipe (PVC) diameter recommended (inches)
0 - 50 m ²	2"
51 - 120 m ²	3"
121 - 200 m ²	4"
> 200 m ²	6"

Table 6.1 — *Appropriate pipe diameter for plumbing network that connects roof, first flush, and cistern, as a function of roof area.*

6.1.3 Sun damage on plastic

Most plastics degrade when exposed to ultra-violet (UV) radiation. Sunlight is full of UV rays. This degradation can lead to a weaker pipe and quick discoloration of a white pipe. The solution is simple: paint the pipes! A water-based latex paint should work as well as any other paint that is UV-proof. Light colors are better, since they reflect more of the sun's energy, but any UV-resistant paint will do.

6.1.4 Structural integrity

Although PVC pipes are lightweight, a pipe full of water becomes quite heavy. Since there are limitless ways to set up your system depending on the location's specific architecture and features, we won't go through examples. However when you are running your tubes from the roof to the first flush, consider the weight of water and make sure that the tubes are supported sufficiently. If there are no available trees, fences, ledges, or structures on which to run the pipe (a common situation) and your pipe is long enough that it needs support, we often find that nailing into the roof and fixing the pipe with steel wire at regular intervals is an effective, simple solution.

6.1.5 Leaf filters

To stop organic material (leaves, twigs, etc.) and animals (i.e. small lizards) from entering the system — as well as mitigating the risk of clogging and dirt build up — all entries and exits should be covered with screens (plastic or galvanized mosquito screen). This type of screen is called a leaf filter. Leaf filters are an important safeguard against biological contaminants. Common places you will see leaf filters:

- On the roof outlets (*figure 6.1a*),
- On the outlet from the gutter system,
- On the inlet into the first flush system (*figure 6.1b*),
- On the outlet of the overflow pipe.



Figure 6.1 — Various leaf filters: (a) an example of a leaf filter installed on the inlet to the gutter system from the roof and (b) the inlet to the first flush.

6.1.6 Heights, gravity, and paths

As you design your piping system, it is critical that water can flow from one point to the next with gravity (requiring at least a 1° slope) and that each level is at an appropriate height (see *figure 6.2*). This is especially important with the 12,000-liter above ground cistern, which is a tall cistern at 2.5 meters high. The tubing from the roof must be above the entrance to the first flush system which then must be higher than entrance to the cistern. Before installing your pipes, consider *figure 6.2* and make sure that levels 1, 2, 3, and 4 are distinct, in order, and can be connected by downward-sloping pipes.

6.2 Specific assembly guidelines

As you plan to assemble your cistern, we hope these guidelines will help you with some of the specific technical details like gluing two pieces of PVC together, making a water-tight connection between threaded pieces, drilling holes that are the correct size, and water-proofing your cisterns and barrels. If you are not familiar with some of these plumbing details, make sure to read the next section closely before beginning your construction process.

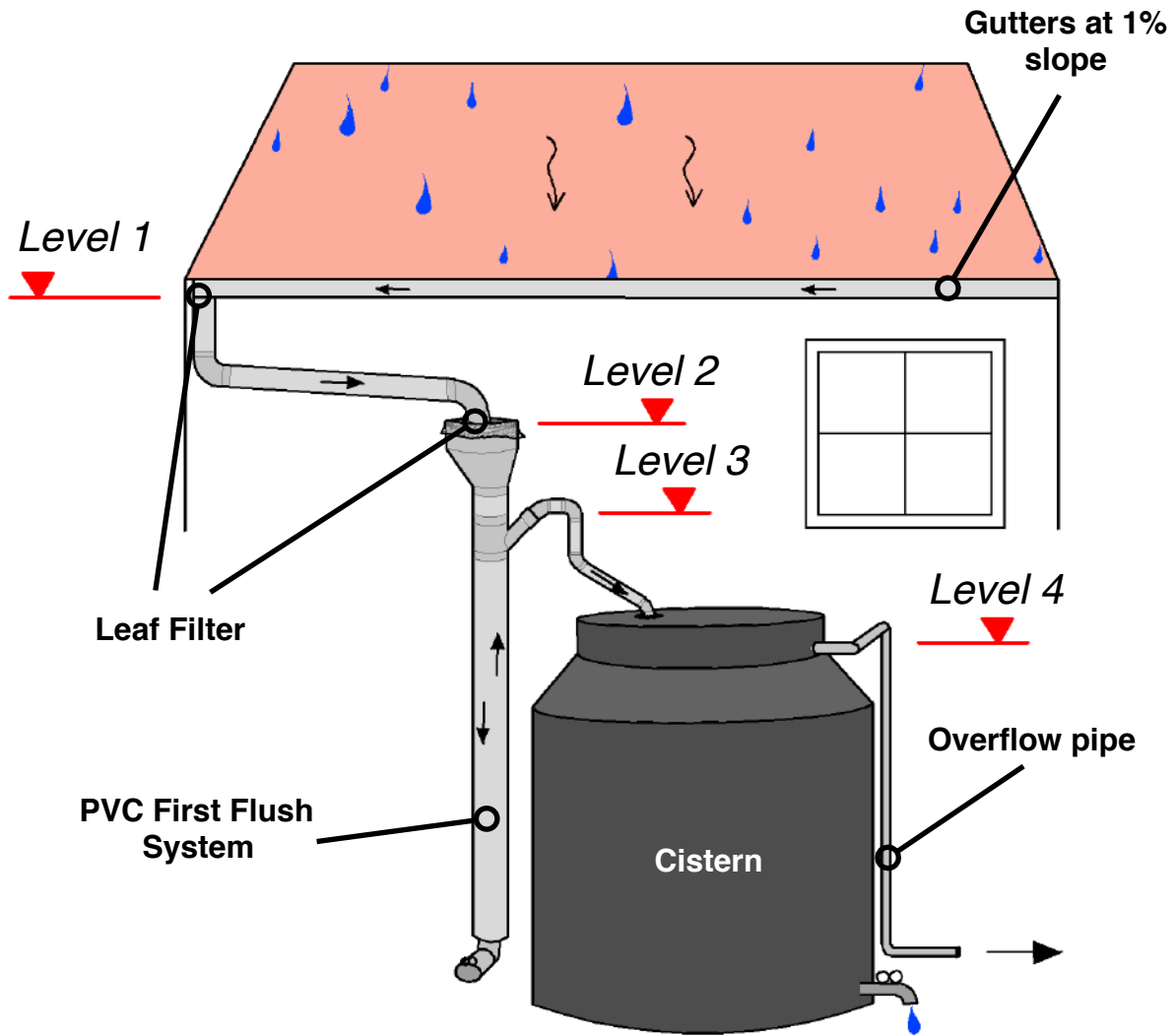


Figure 6.2 – Make sure the gutter outlet (Level 1) is higher than the first flush inlet (Level 2). The first flush inlet (Level 2) must be higher than the first flush outlet/cistern inlet (Level 3). And the cistern inlet (Level 3) must be higher than the cistern overflow (Level 4).

6.2.1 Drilling holes for fittings

When you are connecting inlets and outlets to a plastic container, like a cistern or a barrel, you need an opening. Some commercial plastic cisterns come with pre-drilled holes and specific fittings. In most low-cost cases, you need to make the hole yourself. The hole can be made with an electric drill, a pocket knife, or a machete.

Key points for success:

1. Cut the hole small and enlarge it slowly with a file or pocketknife. If the hole is too large, it is more difficult to waterproof and your system is more likely to develop a leak.
2. Use a file or pocketknife to smooth the edges of the hole as well as possible. If the hole isn't circular, it is more likely to leak.
3. When working with a softer plastic than PVC, like HDPE, you can often screw a PVC fitting directly into the wall. This leaves little room for leaks and allows a tight fit.

Once you cut holes in your barrel or cistern, you are ready to attach a piece that connects the container to a valve or pipe. The next section discusses some options.

6.2.2 Bulkhead fittings vs. internally/externally threaded PVC couples

Once you have created an appropriately sized hole in your barrel or cistern, it is time to insert a fitting. We prefer using bulkhead fittings as shown in *figure 6.3b*. They have interior and exterior threads; don't need any PVC cement or silicone; can be easily removed for adjustments and come with a rubber gasket. They tend to be more expensive and harder to find than standard PVC components in many parts of the world, so we often find ourselves work with PVC. If you use internally and externally threaded (often called "male" and "female") PVC adapters (*figure 6.3a*), here are a few design tips:



Figure 6.3 — Container connections
(a) an internally/externally threaded (female/male) PVC connection is the most commonly available way to enter/exit a container, but
(b) a bulkhead fitting, despite its cost, has many advantages.

1. Although PVC is standardized, there are subtle differences. Check that your adapters screw all the way into one another. Pictured in *figure 6.3a* are hydraulic PVC adapters. We have often had more luck with CPVC adapters as they tend to create tighter fit.

2. PVC adapters do not usually come with a seal, but you will need a seal to waterproof a connection. You can (a) buy the appropriately sized gasket or (b) seal the opening with silicone (see the next section).
3. These PVC adapters are typically only threaded on one side. To connect anything to your drum, you will need to glue it in with PVC cement. Do this at final installation since when you twist the female and male adapters together, you do not know how your final setup will be aligned. An upside down valve can be a usability nightmare.

6.2.3 Gaskets, o-rings, & silicone

To make water-tight connections, especially in holes in tanks as described above, a piece of PVC is not sufficient. To avoid leaks, you need a material that can hold under pressure and fill gaps — the circular hole that you cut probably wasn't 100% perfect!

Two choices for sealing are: gaskets (sometimes called “rubber washers”) and silicone. A gasket is a flat rubber ring that compresses to fill a hole. Silicone is typically sold as a gel that you compress around an opening. When it dries, it becomes waterproof and holds its shape well, especially under pressure. When possible, we encourage using gaskets. They are not as permanent as silicone. Silicone will do the job but often takes days to dry and test and is hard to fix when a leak does occur.



Figure 6.4 — (a) a gasket, (b) a tube of silicone, and (c) an o-ring

Gaskets and o-rings are often confused. An o-ring is an appropriate waterproofing tool when there is a slot. Without a slot to set the o-ring into, it will deform and will not provide any water proofing at all. See figure 6.4 for the differences between gaskets, silicone, and o-rings.

6.2.4 Strong PVC connections

When connecting PVC **pipe and smooth fittings**, it is important to have a tight, waterproof connection. To do so, follow the following steps:

1. Fit the pieces together *without* any glue or primer. Make sure the connections are snug and aligned properly.
2. Disconnect the pieces.
3. Clean both pieces with a dry cloth.
4. Roughen the surfaces with a piece of sand paper (if available).
5. *Optional:* If you choose to use primer, apply a coat to each surface and let dry.
6. Quickly apply an even coat of PVC cement to both pieces and insert them together, one quarter turn *out of alignment*.
7. As you insert, turn them the quarter turn into alignment, to evenly distribute the PVC cement within the joint. Stop turning once you reach the fully connected position.
8. Wipe off excess cement and hold firmly in place for 30 seconds to allow the PVC cement to begin setting.
9. Allow to set for as long as is recommended on the PVC cement's packaging.

If you are connecting **threaded fittings**, however, you do not need adhesive. Follow this process:

1. Screw the pieces together *without* any glue or primer. Make sure the connections are snug and aligned properly.
2. Wrap teflon tape clockwise around the externally threaded ("male") piece until the shape of the threads is slightly obscured, usually 3 - 7 wraps.
3. Screw the pieces together, tightening with a wrench if necessary.

Always to test your PVC connections for leaks once the glue has set and again once the system is in operation.

6.3 System photos

We hope that the following photos of real projects will inspire you when designing your own rainwater harvesting systems!





You have now set up your cistern, gutters, first flush, and tube connections. Your system is ready to start harvesting healthy rainwater! To learn how to ensure that your water is safe for human consumption, check out the next chapter on methods of treating water for biological contaminants.

Chapter 8. Maintenance

In the previous chapters, we learned how to build a cistern and install all of the components of an effective rainwater harvesting system. If this system is not maintained, however, it can degrade, bacteria can build up, filters can fail, pipes can rupture, and the quality of water will decline. In this chapter, we will learn how to maintain our system over time.

This section will cover the maintenance of:

- 8.1 The roof
- 8.2 Leaf filters
- 8.3 Gutters & piping
- 8.4 First flush system
- 8.5 Cistern
- 8.6 Caminos de Agua ceramic candle filter

8.1 The roof

Sweep and brush your roof at least once a year. If you use the roof as a terrace, clean it more frequently, we recommend once a month. Prune all the trees around your roof to avoid accumulation of debris and bird poop. Avoid animals/pets on the roof as much as possible.

8.2 Leaf filters

Check the leaf filter(s) once a week during the rainy season. Remove the accumulated leaves once a week. Replace leaf filters every year.

8.3 Gutters & piping

Clean the gutters once a year. Check the pipes monthly. Make sure all connections are in good condition and that there are no leaks in the piping system.

8.4 First flush system

Keep the tap of the first flush system open during the first rain of the season. The first waters should not enter your cistern. For the following rains, close the tap. If your first flush is sized appropriately (see chapter 5) empty it after each rain. After each rainy season, open the tap so that nothing is collected from the next season's first rain.

8.5 Cistern

Cover all the entrances and exits of the cistern with screens so that insects and animals can not enter. Just before the first rainfalls in the rainy season and once the water level is below the level of the cistern tap, it is time to clean the inside of the cistern. To do so, remove the 2" cap on the bottom of the cistern to open the 2" flush out valve. This will empty the remaining water in the cistern. Then enter the cistern through the door on the roof and clean the inside of the cistern with chlorine. Replace the the 2" cap on the flush out valve with teflon tape. Be sure to tighten the cap as much as possible and use teflon tape on the threads. Reconnect the piping to your rainwater harvesting system, and prepare to capture the next season's rains.

8.6 Caminos de Agua ceramic candle filter

Whenever the filter begins looking discolored, fill the carboy to the filter level with water and scrub the filter gently with an old toothbrush to remove any growth, sediment, or residue. Swirl and dump this water.

Once a month, clean the base with a gentle disinfectant. We recommend antibiotic dish soap and water. Allow to dry completely before resuming use.

With the appropriate maintenance steps taken, your rainwater harvesting system will continue to provide safe, healthy water for human consumption for years to come.

Chapter 7. Biological treatment

The previous chapters cover how to make a resilient, robust system to capture and store healthy rainwater for drinking, cooking, and other household uses. However, just because the rainwater is healthy — free from mineral, metal, and other chemical contaminants — it is not necessarily safe to drink. As the water passes from your roof through the piping system, it can easily be contaminated with bacteria, viruses, and other biological pathogens. This chapter offers a few different methods to assure your water is as safe as possible to drink.

What are waterborne biological pathogens? They include everything from the “large,” like parasites and helminths, to the tiny viruses and protozoa. These creatures, most of which are too small to see with the naked eye, live in watery environments. Some of them also live and reproduce in the human body and can make us sick. In 2015, according to the World Health Organization, about half a million people died from diarrhea caused by waterborne biological pathogens, mostly bacteria and viruses. About 300,000 children under the age of five die every year from drinking unsafe water.

There are two options to make water safe from biological pathogens. The first is to mechanically remove all of the pathogens with a physical filter. These filters are specially designed with holes or pores tiny enough to allow water to pass, but to exclude even the tiniest of organisms. However, filters clog over time and often require high pressures. The second method is to kill the pathogens. Biological organisms can only harm you when they are alive; they rarely affect the taste, smell, or color of the water. The majority of widely used, low-cost treatment methods (like chlorine and slow sand filtration) rely primarily on this second strategy.

This chapter describes:

- 7.1 Practical low-cost treatment methods
- 7.2 Safe water storage
- 7.3 Higher-cost or proprietary treatment methods
- 7.4 Connecting your rainwater system to treatment & storage

7.1 Practical low-cost treatment methods

The following pages highlight various treatment methods for making drinking water safe from biological contaminants. Each section details the system's advantages and disadvantages and provides more resources. Often the cheapest and easiest method is to purchase a low-cost filter. The majority of commercial water filters remove biological contaminants, but you should still consult a trusted plumber or water specialist to be sure. Choose a system that works best for you.

The following filtration and disinfection methods are relatively low-cost and practical to either purchase locally or build yourself. This manual is *not* intended as a construction guide for filters and disinfection systems! It is an education tool you can use to select an appropriate treatment method for your community, culture, and context.

Each of the following methods has a brief summary of how the method functions followed by sections describing the effectiveness, the lifestyle changes required, and the cost. In these sections, we are explicitly focused on methods that *remove biological contaminants from rainwater*. We do not focus on turbidity (sediment like sand, silt, leaves, dirt, etc.) nor chemical contaminants like agrochemicals, minerals, or metals. Finally, this section does not treat rarer contaminants like radioactive elements or atmospheric industrial pollutants. If you have any of these contaminants in dangerous concentrations in your rainwater, you should not consume it! If you are looking for general low-cost water treatment resources for surface water, groundwater, grey water, black water, industrial waste, or any other water source that needs to be treated, see the following resources or any of the thousands of others you can find online:

1. Biological treatment, turbidity, some minerals — Center for Affordable Water & Sanitation Technology (CAWST) <https://resources.cawst.org>
2. Waste water (grey and black) — Bremen Overseas Research & Development Association (BORDA) <http://www.borda-sea.org/basic-needs-services/dewats-decentralized-wastewater-treatment.html#c2155>
3. Arsenic — Kanchan Arsenic Filter (KAF) <http://web.mit.edu/watsan/Docs/Other%20Documents/KAF/KAF%20booklet%20final%20Jun05.pdf> and
4. Fluoride — Caminos de Agua <http://caminosdeagua.org/biochar-water-treatment/>
5. Household and industrial wastewater — US Environmental Protection Agency (EPA) Guide on constructed wetlands <https://www.epa.gov/sites/production/files/2015-10/documents/constructed-wetlands-handbook.pdf>
6. Household wastewater and passive rain collection — Watershed Management Group <https://watershedmg.org/learn/resource-library>
7. Synthetic organics like pesticides and herbicides — Aqueous Solutions <http://www.aqsolutions.org>

7.1.1 Boiling

Pros

Effective on all pathogens
Easy to use
Inexpensive

Cons

Concentrates minerals and metals in water
With wood or charcoal, leads to deforestation
Pollutes with smoke

Method

Boiling is considered the world's oldest and is one of the most common and effective methods for disinfecting water. Pathogens are killed when the temperature reaches 100 degrees Celsius (212 degrees Fahrenheit). The Center for Affordable Water and Sanitation Technology (CAWST) recommends boiling for one minute and adding an additional one minute for every 1000 meters of elevation above sea level.



Image courtesy of CAWST

Effectiveness

- Quality:** Very effective at killing all pathogens
- Quantity:** Depends on the size of the pot
- Water:** Can be used with any biologically-active water. Note that boiling water *increases* the concentration of dissolved contaminants!

Lifestyle factors & cost

- Resources:** Different fuel sources may be locally available (i.e. wood, charcoal, biomass, gas, electricity).
- Time:** Need to heat water until it boils for at least one minute. The time required changes with altitude, quantity of water, and fuel source.
- Dangers:** Potential for burn injuries; respiratory infections and other illnesses associated with poor air quality; pollution from burning carbon.
- Lifespan:** Pots and stove may need to be replaced; When using firewood, needs to be collected or purchased regularly.
- Water aesthetic:** Some people believe that boiled water tastes “flat.” Others have reported “smoky.” Boiling does not typically change smell or color.
- Ease of use:** Fuel collection is an investment of time which could be used for other purposes.
- Initial cost:** Free or low-cost — households can use existing pots.
- Operating cost:** On-going cost for fuel, cost varies depending on region and fuel type.

7.1.2 Solar disinfection (SODIS)

Pros

Effective on all pathogens
Simple setups with no moving parts
Inexpensive

Cons

Can take at least two days
Will not work on overcast or rainy days
Requires non-turbid water

Method

SODIS uses radiation from the sun to kill pathogens in the water. It can be used to disinfect small quantities of water with low turbidity. Fill transparent, non-colored plastic bottles made from polyethylene terephthalate (PET) and place them in direct sunlight. Water can be used directly from the bottles to avoid recontamination.

Effectiveness

Quality: Very effective at killing all pathogens

Quantity: 1-2 liters per bottle, as many bottles as you want

Water: Can only use with clear, non-turbid water. Works well with rainwater.

Lifestyle factors & cost

Resources: 1-2 Liter plastic bottles are available in most places.

Time: The bottles must sit in direct sunlight for at least six hours on a sunny day and at least two full days when cloudy. You cannot use SODIS when it is raining.

Dangers: Plastics break down over time and leach.

Lifespan: Bottles must be replaced if they have many scratches.

Water aesthetic: SODIS makes the water warm. It does not change the color, smell, or taste.

Ease of use: Simple.

Initial cost: Free or low-cost — households can use recycled plastic bottles.

Operating cost: None.



Image courtesy of CAWST

7.1.3 Biologically active slow-sand filtration

Pros

Made from common local materials globally
Simple setups with no moving parts
Inexpensive

Cons

Only somewhat effective on viruses
Difficult to transport
Lag-time for biolayer to develop

Method

A “biosand” filter is a concrete or plastic box that is filled with layers of sand and gravel. Water is poured into the top of the filter and collected in a safe storage container after filtration. Pathogens and turbidity are removed by physical and biological processes in the sand.

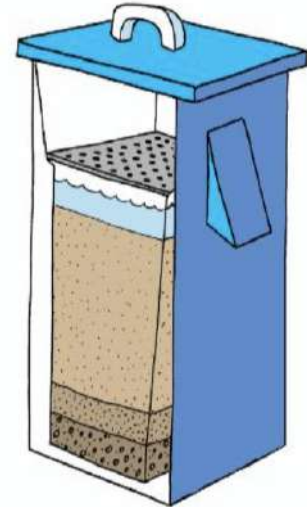


Image courtesy of CAWST

Effectiveness

Quality: Very effective at killing large pathogens
Somewhat effective at killing viruses

Quantity: 12-18 Liters per day as pictured. Other designs have variable flow up to ten of thousands of liters per day.

Water type: Can be used with any water source without much turbidity.

Lifestyle factors & cost

Resources: Concrete filters can be constructed anywhere in the world. Plastic filters can be purchased or made from recycled drums.

Time: Concrete: 0.6 liters / minute; Plastic: 0.8 liters / minute. However you must wait many hours between 12-18 liter batches.

Dangers: Does not remove viruses completely.

Lifespan: Concrete: 30+ years if not moved; Plastic 10+ years. Lids and diffuser plates may need to be replaced.

Water aesthetic: No change or improved.

Ease of use: Easy for adults. May be difficult for children to fill the filter.

Initial cost: Concrete: \$12-30 USD; Plastic: \$75 USD for 12-18 liters per day
Variable for larger sizes.

Operating cost: None.

7.1.4 Ceramic pot filtration

Pros

Effective on all pathogens
Simple setups with no moving parts
Inexpensive

Cons

Quality depends on manufacturer
Difficult to transport

Method

Ceramic pot filters are usually made from clay mixed with a combustible material like sawdust, rice husks, or coffee husks. Colloidal silver is sometimes used to help with pathogen removal. Water is poured into the ceramic pot and is collected in another container for safe storage.

Effectiveness

Quality: Very effective if colloidal silver is used, somewhat effective if not

Quantity: 8 liters in each batch

Water: Can be used with any water source without much turbidity, good for rainwater.

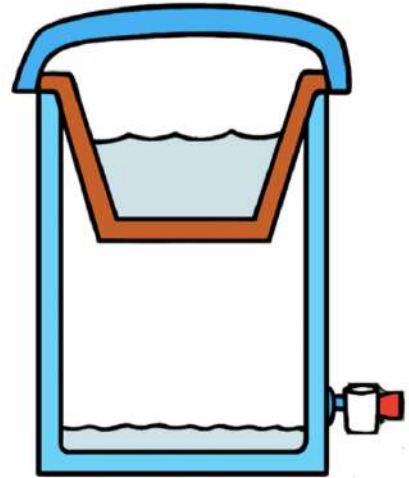


Image courtesy of CAWST

Lifestyle factors & cost

Resources: Can be manufactured and purchased locally

Time: 1 - 3 liters / hour,

Dangers: None.

Lifespan: Up to 5 years. Usually 1 - 2 years. Needs to be replaced if there is visible cracking

Water aesthetic: No change or improved.

Ease of use: Easy to use. Easy to maintain by scrubbing when flow rate slows.

Initial cost: \$12 - 25 USD

Operating cost: None.

7.1.5 Chlorine

Pros

Very effective on bacteria
Quick
Inexpensive

Cons

Requires regular chemical dosing
Is not very effective for protozoa & helminths
Changes the water's taste

Method

Chlorine is a popular chemical used to disinfect water. Sodium hypochlorite and sodium dichloroisocyanurate or sodium troclosene are different types of chlorine (which are abbreviated as NaDCC) that are available. When added to water they release hydrochloric acid which reacts with microorganisms and kills them. There are different brands of chlorine products that are specially manufactured for household water treatment.



Image courtesy of CAWST

Effectiveness

Quality: Very effective in removing bacteria.
Not effective for certain types of protozoa. Protects water against recontamination.

Quantity: Depends on container size.

Water type: Should only be used with clear water, effective for rainwater.

Lifestyle factors & cost

Resources: Available for purchase in most places

Time: Need to wait at least 30 minutes after adding chlorine.

Dangers: Over-dosing chlorine can be harmful. Chlorine gas is toxic. Keep chlorine away from children.

Lifespan: Up to 5 years for tablets. Liquid chlorine products should be used within 3 months of manufacture.

Water aesthetic: Changes the taste.

Ease of use: Follow manufacturer's instructions for specific product.

Initial cost: None.

Operating cost: \$3 - 11 USD per year depending on the product choice.

7.1.6 Distillation

Pros

Extremely effective on *all* contaminants

Cons

Slow
Very energy intensive
Leaves a waste product

Method

Distillation is an ancient method of using energy to treat drinking water. It is the process of evaporating water into vapor, then capturing and cooling the vapor so it condenses back into a liquid. Any contaminants in the water are left behind when the water is evaporated. There are many different designs for distillation stills, some of which are solar.

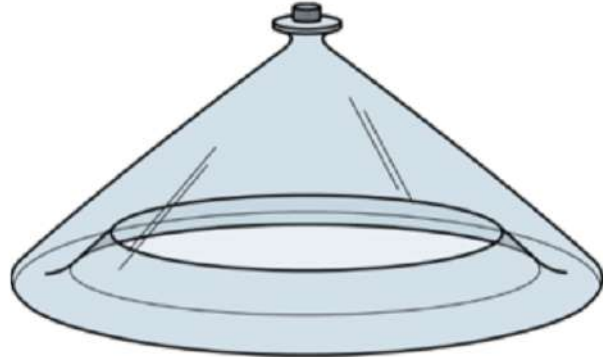


Image courtesy of CAWST

Effectiveness

- Quality:** If done properly, very effective in removing all contaminants
- Quantity:** Depends on size of still
- Water type:** Can be used with any water source. Is probably unnecessary for rainwater, but would work.

Lifestyle factors & cost

- Resources:** Can be purchased from a manufacturer or built with local materials
- Time:** Depends on still. Cannot use a solar still in the rain.
- Dangers:** Water has no minerals which can be a source of needed essential nutrients.
- Lifespan:** 5-10 years depending on the type and quality of still
- Water aesthetic:** Some people believe that distilled water tastes flat.
- Ease of use:** Depends on still
- Initial cost:** Wide range depending on still design
- Operating cost:** None.

7.1.7 Ceramic candle filtration*

Pros

Effective on all pathogens
Simple setups with no moving parts
Inexpensive

Cons

Quality depends on manufacturer

Method

Ceramic candle filters are hollow cylinders made from a clay mixed with a combustible material like sawdust. Colloidal silver or another antibiotic chemical must be added to help with pathogen removal. One or more candles are attached to the bottom of a container. Water is poured into the container, flows through the candle where the pathogens are trapped or killed, then collected in another container for safe storage.



Image courtesy of CAWST

Effectiveness

Quality: Very effective if colloidal silver is used, somewhat effective if not

Quantity: 2 - 8 liters / hour

Water: Can be used with any water source without much turbidity, good for rainwater.

Lifestyle factors & cost

Resources: Can be manufactured and purchased locally

Time: 2 - 8 liters / hour,

Dangers: None.

Lifespan: 3 - 5 years. Candle needs to be replaced if there are any visible cracks or wear.

Water aesthetic: No change or improved.

Ease of use: Easy to use. Easy to maintain by scrubbing when flow rate slows.

Initial cost: \$15 - 30 USD

Operating cost: None.

**For more information on Caminos de Agua's ceramic candle water filters, see section 7.1.8.*

7.1.8 Caminos de Agua's ceramic candle filter

Ceramic water filtration has been used around the world for thousands of years to make potable water. Traditional ceramic filters were most often made in the shape of a bowl, as shown in section 7.2.4.

The original design for Caminos de Agua's ceramic candle filters was done by Dr. Robert Márquez, a soil, clay, and engineering specialist. The candle shape is stronger and more compact than pot-shaped filters. The walls of this filter are 40% thicker than an average ceramic filter (1.85 cm versus 1.3 cm), giving a factor of safety of 1.4. The filters can be manufactured from local materials with a simple mold that is available worldwide without any specialized mechanical equipment.

The filters are made from a mix of clay and sawdust. The sawdust is burnt to smoke when the filter is fired in a kiln, leaving a porous clay filter behind. The sawdust size determines the filter's porosity. The pores must be small enough to trap large bacteria, between 0.6 and 3.0 microns. To make sure that no biological pathogens pass through the filter to harm humans, we also impregnate the structure with an antibacterial agent: colloidal silver. Caminos de Agua recommends changing the filter after three to five years of regular use as the clay degrades over time or if you see any visible cracking. The filters are installed into recyclable plastic containers with food-grade silicone. The containers sit atop a plastic or ceramic base that can hold nine to twelve liters of safe, treated drinking water.



Figure 7.1 — Caminos de Agua's ceramic water filter with ceramic base for safe water storage.

Caminos de Agua has spent years testing the science behind the filters and their efficacy in independent laboratories, universities, and government agencies.

Capacity: These ceramic water filters can filter between two and eight liters per hour. An average household will filter about 24 liters per day. Over a three year lifetime, these filters will remove bacteria, viruses, protozoa, helminths, other biological pathogens, and all turbidity from over 26,000 liters of safe drinking water. The filters achieve and surpass Mexican, US-EPA, and international potable water quality standards.

Value: The average cost of buying water is about \$30 MXN for a 20 liter bottle or roughly 1.5 pesos per liter. By

contrast, a ceramic filter can provide 24 liters of drinking water per day for three years for a startup cost of \$525 MXN. If we assume that you are only getting 20 liters from the filter every day, it becomes cheaper than buying bottled water once you have used it for three weeks. They last three to five years. That's 35 to 59 months of free safe, healthy drinking water.

Note: *These ceramic candle filters, like the other filters in this section, ONLY remove biological pathogens and turbidity. They DO NOT remove chemical contaminants (pesticides, herbicides), minerals (fluoride, magnesium), metals (arsenic, lead, mercury), or dissolved solids (salt, chlorine). If you have dangerous levels of contaminants like these in your water, we highly recommend capturing rainwater! If you have dangerous levels of these in your rainwater, see section 7.3 on reverse osmosis.*

CAMINOS DE AGUA CERAMIC FILTERS: TESTING & CERTIFICATION						
Institution	Location	Type of test	Before filtration	Acceptable criterion	Post-filtration results	Safe?
CONAGUA (México federal water commission)	Celaya, Gto., México	Total coliforms	46,000.00 NMP/100mL	≥99.99% reduction	No detect	✓
		Fecal coliforms	24,000.00 NMP/100mL	≥99.99% reduction	No detect	✓
		Turbidity	28 UTN	5 UTN	1 UTN	✓
Querétaro state water commission	Querétaro, Gto., México	E. Coli	120,000 UFC/100mL	≥99.99% reduction	100.00% removal	✓
		Total fecal coliforms	120,000 UFC/100mL	≥99.99% reduction	100.00% removal	✓
		Aerobic mesophiles	32,467 UFC/mL	≥95.00% reduction	99.98% removal	✓
		Turbidity	615 UNT	5.0 UNT	1.0 UNT	✓
		Color	1,500 Pt/Co	20.0 Pt/Co	2.5 Pt/Co	✓
University College of London	London, England	E. Coli	3,110,000.00 UFC/100mL	≥99.99% reduction	99.9999% removal	✓
EcoLaboratorios S.A. de C.V. Environmental Research	Salamanca, Gto., México	Total fecal coliforms	>1,100 NMP/100mL	No detect	No detect	✓
		Turbidity	483 UNT	5.0 UNT	0.71 UNT	✓
Columbia University, Department of Engineering	New York, New York, USA	E. Coli	131.4 NMP/100mL	< 1.0 NMP/100mL	< 1.0 NMP/100mL	✓
Caminos de Agua laboratory	Atotonilco, Gto., México	Total fecal coliforms	> 2419.6 NMP/100mL	< 1.0 NMP/100mL	< 1.0 NMP/100mL	✓
		E. Coli	> 2419.6 NMP/100mL	< 1.0 NMP/100mL	< 1.0 NMP/100mL	✓
Caminos de Agua field testing	Various locations	Total fecal coliforms	> 2419.6 NMP/100mL	< 1.0 NMP/100mL	< 1.0 NMP/100mL	✓
		E. Coli	> 2419.6 NMP/100mL	< 1.0 NMP/100mL	< 1.0 NMP/100mL	✓

Table 7.1 – Results of testing on Caminos de Agua’s ceramic candle water filter by various government agencies and private institutions.

7.2 Safe water storage

Once you treat your rainwater for biological contaminants, it is crucial to use some form of safe water storage to ensure that you and your household or community have safe drinking water.

Treated water is often recontaminated through contact with dirty hands or utensils, like cups and ladles. Figure 7.2 shows some small-scale, inexpensive methods for safe in-home water storage. Below are a few basic characteristics that all safe water storage containers should share:

1. Covered

Any safe water storage container should be covered to prevent things from falling into it. After treating water for biological pathogens, leaves, dust, bird feces, spiders, flies, and so on could all recontaminate the water with bacteria. Your storage should be covered as well as possible — it is best to use a lid that fits tightly. In a pinch, you can use a plate, a clean pot, or a towel to cover your water storage container.

2. Easy to serve water

To prevent recontamination, it should be easy to serve water from the storage container without touching any of the openings or the water that remains inside. You can use an easily pourable pitcher-type design or, as we recommend, a container with a valve near the bottom. Make sure that when people remove water, they do not touch the water that will remain in the container with their hands or any utensil.

If you need to dip: if you cannot pour or use a valve or tap, you can dip a utensil into your storage container. Always use a clean cup or vessel for dipping. It is safer to have a permanent dipper from which no one ever drinks. We strongly urge against dipping whenever possible.

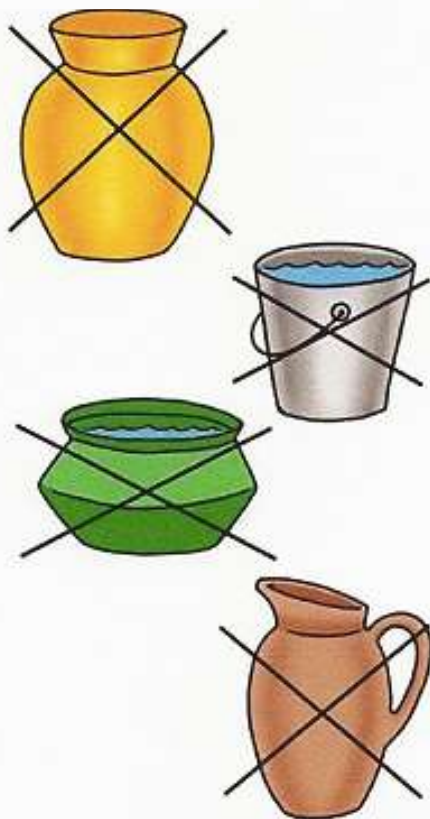
3. Easy to clean

The storage container should be easy to clean in case it begins growing algae or smelling. Usually a few rinses with clean water will work, but occasionally you should scrub with a brush or use an antibacterial agent like chlorine. Wide openings and simple shapes like a cylinder, urn, or bucket facilitate cleaning.

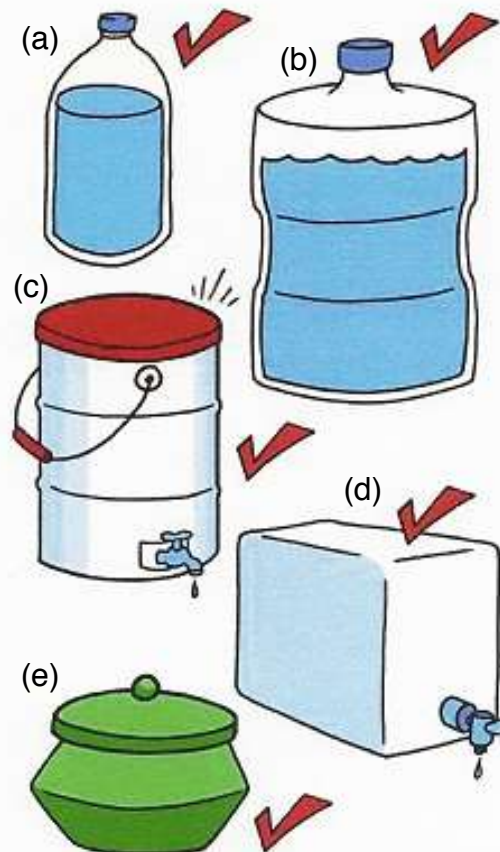
4. Opaque or shaded

To prevent algae growth, your container should be either opaque (does not let sunlight through) or kept in the shade or indoors. Always keep plastic containers out of the sun — they degrade with UV radiation.

Source: CAWST



Improper storage containers



Proper storage containers

Figure 7.2 – Unsafe (left) and safe (right) water storage containers.

All the containers on the right are covered and easy to pour from or have an accessible tap. Containers (a) and (b) are safe, but may be difficult to clean because of their small mouths and need to be kept in the shade. Container (d) may be difficult to fill. Container (e) is safe with a safe dipping utensil, but can be difficult to manage. We recommend using a container similar to container (c). Its wide mouth makes it easy to fill and clean, while its lid makes it safe from airborne contaminants. The tap at the bottom is accessible and prevents the user from contaminating stored water.

7.3 Higher-cost and proprietary treatment methods

There are too many different filtration methods to mention all of them in this section. Please note that the vast majority of filtration methods will remove sediment, turbidity, and biological contaminants, *nothing more*. There *are* some more specialized filters that remove specific contaminants, like an activated carbon filter that removes trace pesticides and herbicides. We need to emphasize: if an expensive filtration system doesn't specifically state what it removes, **DO NOT ASSUME THAT YOUR WATER IS SAFE**. Check out the filter's details and specifications online and try to find third-party studies on the filter's efficacy.

The only methods that remove almost all contaminants to a safe and healthy level are **distillation** (section 7.2.7) and **reverse osmosis**. As explained in the previous section, distillation is energy-intensive and often expensive, but yields the most pure water of any treatment method. (This is the same process we see with rainwater: On Earth, rain is formed from surface water using the same distillation technique, making rainwater some of the safest and healthiest water available, if collected, treated, and stored properly.) Reverse osmosis (RO) uses pressure to push water through a membrane with tiny pores, leaving most contaminants — including those as small as ocean salt! — behind. RO systems can be expensive, need constant electricity, and require regular membrane replacement. If you cannot capture rainwater, an RO system is a decent, albeit less environmentally sustainable, method for providing safe and healthy water from widely contaminated surface or groundwater, since it removes almost all contaminants. If you have lots of metals, minerals, or organic contaminants in your water, RO is a safe, catchall filtration method.

Other, more expensive and specific water treatment methods include, in no particular order: ultraviolet (UV) disinfection, iodine dosing, ultrafiltration, proprietary chlorine tablets, granular or powdered activated carbons (GAC & PAC), and remineralization steps, among many other water treatment techniques. Again, we need to emphasize: *Know the facts. Learn what contaminants are in your water, if they are dangerous or unhealthy to consume at the current levels, and whether your treatment system effectively removes them.*

7.4 Connecting your rainwater system to treatment & storage

There are infinite ways to connect your rainwater cistern to a biological treatment step and a storage container, limited only by your plumbing creativity. This section outlines a few methods that we commonly see in central Mexico, but is not a comprehensive list.

One choice is not to connect your cistern to the treatment step. When Caminos de Agua works on rainwater systems, our ceramic water filters — complete with attached ceramic or plastic base for safe storage (see figure 7.1 and the diagram in section 2.1) — are included. Users carry water from their outdoor cisterns to fill their ceramic filters. The water slowly drips through the filter and fills the base.

Another common option is to install copper or PVC piping connecting the cistern to the house with a tap to fill the filter. This requires your cistern to be slightly uphill from the tap, to take advantage of gravity. This is an excellent option if you are capturing rain in one place and then running the water to many sites downhill, like classrooms in a school or community center, where each room has a treatment system.

Another common option is to pump the water to a smaller cistern on the roof, for gravity-driven distribution through the building. You can do so using any pumping method including hand pumps, bicycle pumps, or electrical pumps. With the water in a rooftop tank, you can route it to different places in the building. Remember, only water for drinking and cooking needs to be filtered! It's no problem to bathe, flush your toilet, water your garden, or wash your clothes with biologically-active water, so you could run one pipe to a potable-grade filter in the kitchen, and pass the rest of the house's water through a lower-tech filter like a bed of sand.

If you have regular access to electricity, it is a common option to connect an electric pump to the cistern to push the water through a treatment step (most often a sediment-carbon-UV system) then through the building. Since this method uses a pump, you are not limited by the cistern location and can pipe the water anywhere in the building. Here, your piping system acts as safe storage, so make sure to use copper or PVC piping that has been certified as safe for potable water.

There are many other ways to connect a rainwater harvesting system to biological treatment and safe storage. When designing your complete system, make sure that you address possible contamination by:

1. Preventing unnecessary biological contamination from your roof by clearing the space (section 2.3), sizing your first flush system appropriately (chapter 5), and using leaf filters (chapter 5).
2. Implementing a proven, effective biological treatment step (section 7.2)
3. Using a safe storage container or system (section 7.3)
4. Ensuring that you have no leaks, gaps, or contamination points where biological organisms could reenter the system.

If you have followed the steps above, and if your roof is safe to collect water from (see section 1.2.2), you have a safe, healthy, and sustainable water source to meet your essential water needs!

Appendix A: Design worksheets



Designing rainwater harvesting systems for communities - calculations & specifications

General Information

Date:		Name of family or representative:			
Tel:		Email:			
State:	Guanajuato	Other:			
Community name/location:					
GPS:					
Municipality:	San Miguel de Allende	Dolores Hidalgo	San Luis de la Paz	San Diego de la Unión	San José Iturbide
	San Felipe	Other:			

Consumption Information

Type of building:	House	Business	Kindergarden	Elementary	Middle School
	High School	Other:			
Number of users:					
Type of consumption (Liters/user/year o L/u/y):	House 1,825 L/u/y	Business 730 L/u/y	Kinder 183 L/u/y		
	Elementary - Middle School 365 L/u/y	High School 730 L/u/y	Other _____ L/u/y		
Annual consumption :	_____	x	_____	=	_____
	<i># of users</i>		<i>L/u/y</i>		<i>Total liters per year</i>

Capturing surface and piping/plumbing

Capturing surface area(s):	Roof #1	Length: <i>m</i>	Width: <i>m</i>	Area: <i>m²</i>
	Roof #2	Length: <i>m</i>	Width: <i>m</i>	Area: <i>m²</i>
	Roof #3	Length: <i>m</i>	Width: <i>m</i>	Area: <i>m²</i>
Total capture surface (the sum of the totals above):				Area: <i>m²</i>
PVC Plumbing & Gutters (inches):	2" <i>(for capture surfaces from 0 - 50 m²)</i>		3" <i>(for capture surfaces from 51 - 120 m²)</i>	4" <i>(for capture surfaces from 121 - 200 m²)</i>

First Flush System

Cleanliness factor:	0.4 <i>(minimum)</i>	0.5 <i>(normal)</i>	2.0 <i>(extreme)</i>	<i>Other:</i>	
Quantity of liters to separate for the first flush system:	$\frac{\text{Total capture surface area (m}^2\text{)}}{\text{Cleanliness Factor}} = \text{Quantity of liters to separate}$				
PVC First Flush System:	PVC Diameter	2"	3"	4"	6"
	Capacity (liter/meter)	2.4	5.4	8.9	18.2
Size/length of PVC First Flush System:	$\frac{\text{Quantity of liters to separate}}{\text{PVC Capacity (liters/meter)}} = \text{Size of first flush system in meters}$				

Maximum annual capture volume

Average annual rainfall:	San Miguel de Allende	Dolores Hidalgo	San Luis de la Paz	San Diego de la Unión	Other
	565mm	463mm	367mm	421mm	
Efficiency factor:	Concrete Roof	Corrugated sheet	Tile	Other	Other (you decide)
	0.85	0.8	0.8	0.75	
Max annual capture volume:	$\text{Annual rainfall (mm)} \times \text{Total capture area (m}^2\text{)} \times \text{Efficiency factor} = \text{Maximum annual capture volume (liters)}$				



Designing a rainwater harvesting system

Sketch

Written, Organized, Translated, and Edited by Caminos de Agua

Casilda Barajas Rocha
Elena Diek
Chantal Kronenburg
Aaron Krupp
Sarah Mitchell
Pilar Quintanilla Martinez
Dylan Terrell
Billy Thurston
Daniela del Villar

Diagrams, Drawings, and Graphic Design

Elena Diek
Aaron Krupp
Billy Thurston

Photography

Janet Jarman
Cameron Plese (cover photo)
Billy Thurston
Selene Trapp

For more information regarding this manual

Caminos de Agua
Allende #5, Colonia Insurgentes, San Miguel de Allende, Gto, México 37712
Tel: 415-154-8091 / Email: info@caminosdeagua.org
www.caminosdeagua.org



Harvesting a Healthy Future
Caminos de Agua, 2018

©2018 by Caminos de Agua. This work is licensed under the Creative Commons Attribution 4.0 International License. To view a copy of this license, visit: <http://creativecommons.org/licenses/by/4.0/>.

